

GOCE-GRAND-2

Project Overview and Status of the GOCE Mission

Reiner Rummel, Thomas Gruber & Jakob Flury

Institut für Astronomische und Physikalische Geodäsie

Technische Universität München

Geotechnologien Status-Seminar
„Observation System Earth from Space“
Bonn – 18. und 19. September 2006

Contents:

- GOCE Characteristics and Mission Status
- objectives and structure of GOCE-GRAND-2
- matrix structure of GOCE-GRAND-2
- embedding of GOCE-GRAND-2 in GOCE mission activities

GOCE Gravity Mission

Acronym:

Gravity and Steady-State Ocean Circulation Explorer

Mission Objectives:

Geoid std.dev. 1cm

Gravity (anomalies) std. dev. 1mGal,

Spatial resolution: 80 km (Lmax= 200)

Launch:

September 2007

Users (Science and Application)

- **solid Earth physics**
- **physical oceanography
and climate research**
- **geodesy**
- **sea level research**

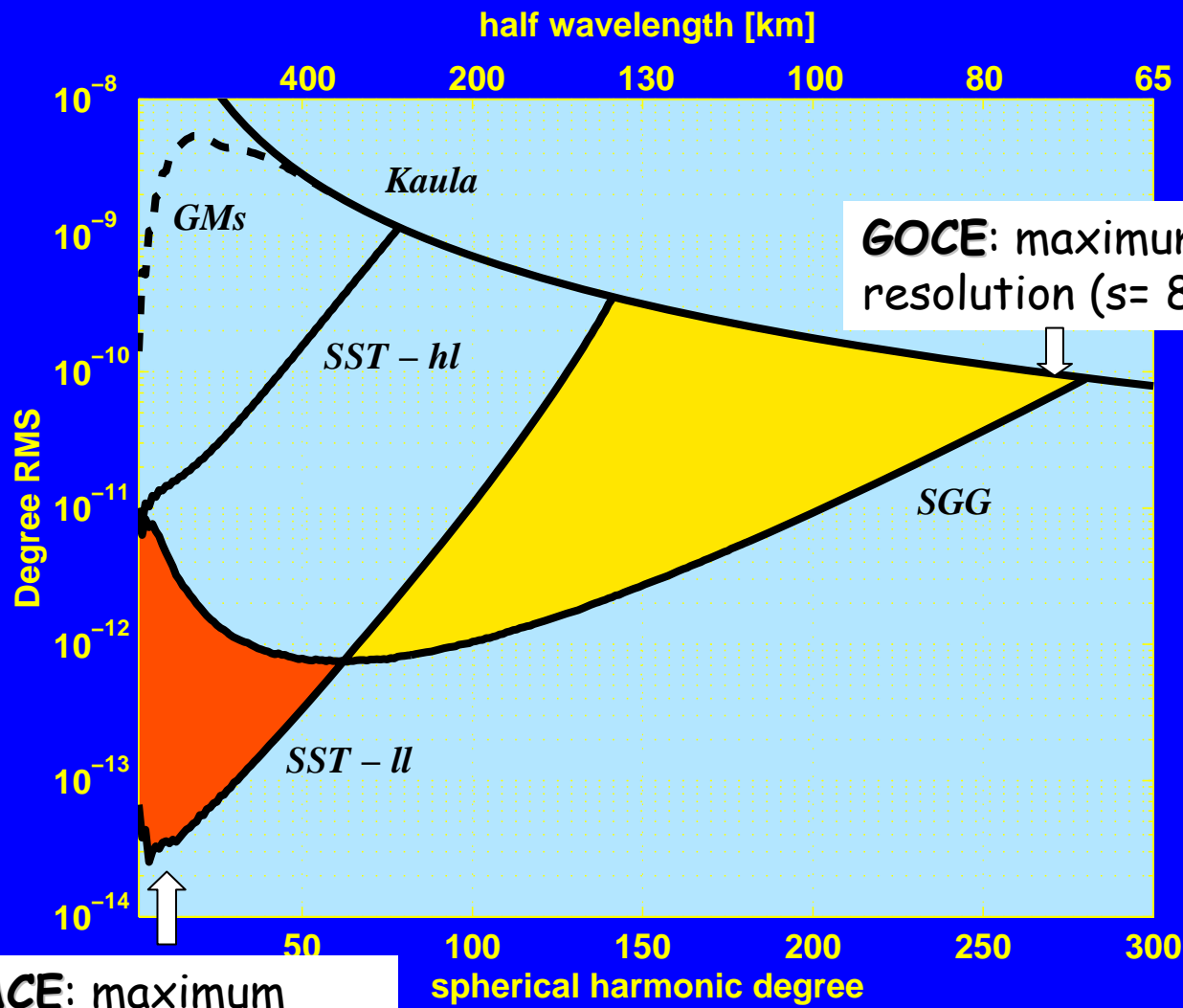

GRACE: maximum precision (geoid $< \mu\text{m}$)

GOCE: maximum resolution (s = 80 km)

Sensor	Measurements
3-axis gravity gradiometer	Gravity gradients Γ_{xx} , Γ_{yy} , Γ_{zz} in instrument system and inside MBW (measurement bandwidth)
	Angular accelerations (highly accurate around y-axis, less accurate around x, z axes)
	Common mode accelerations
Star sensors	High rate and high precision inertial orientation
GPS receiver	Orbit trajectory with cm-precision
Drag control with 2 ion thrusters	Based on common mode accelerations from gradiometer data
Angular control with magnetic torquers	Based on angular rates from star sensors and gradiometer
Orbit altitude maintenance	Based on GPS orbit
Internal calibration of gradiometer (and quadratic factors)	Random shaking with cold gas thrusters (and random pulses)

Status of GOCE development

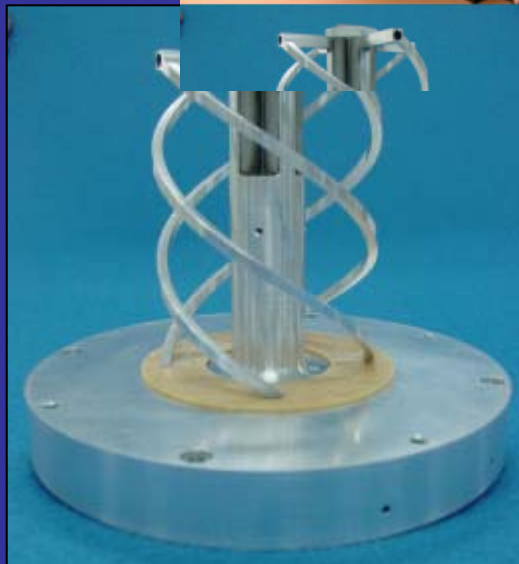
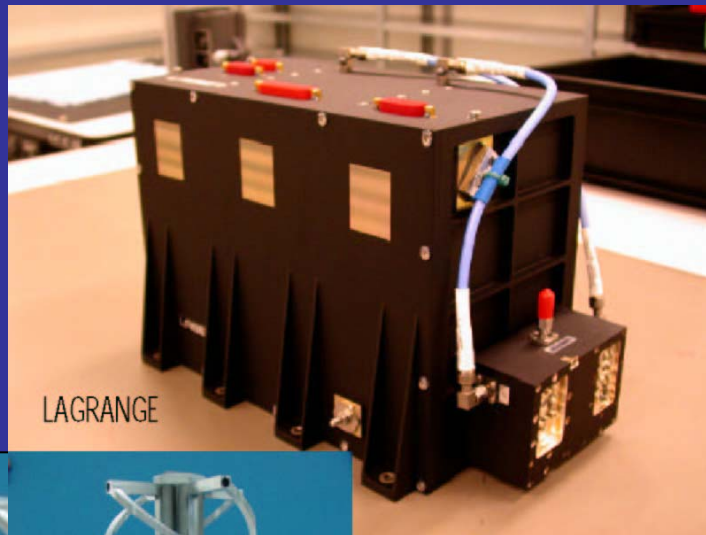

**newly developed
GPS receiver**

**laser
tracking**

Status of GOCE development



**Attitude and
Drag-free control**



Status of GOCE development

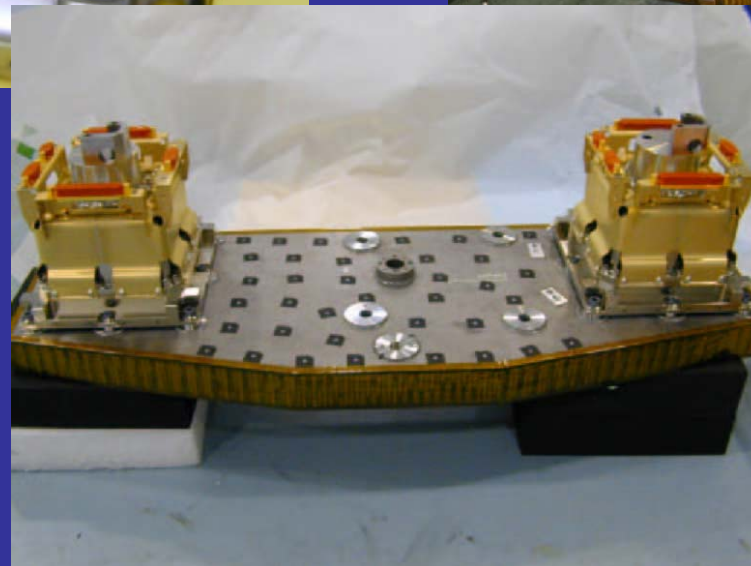
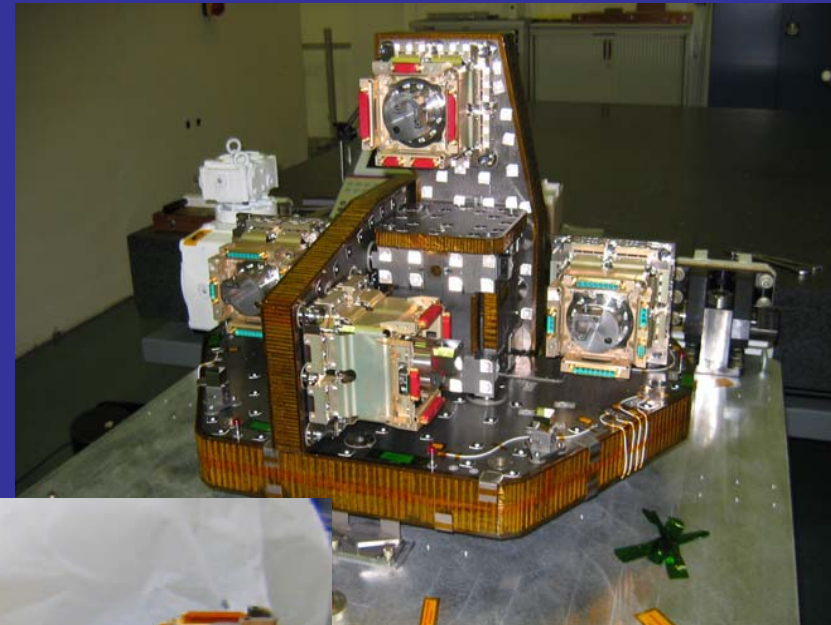
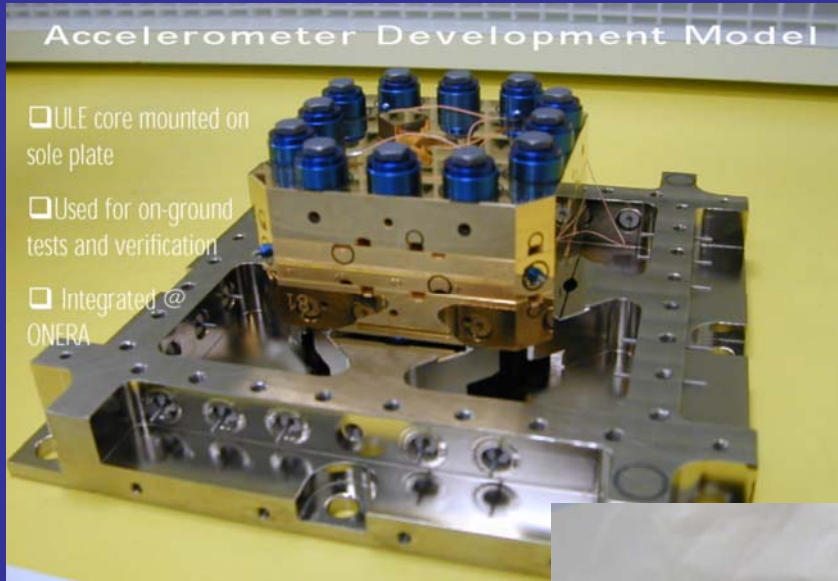

**accelerometers,
1-axis gradiometer
3-axis gradiometer**



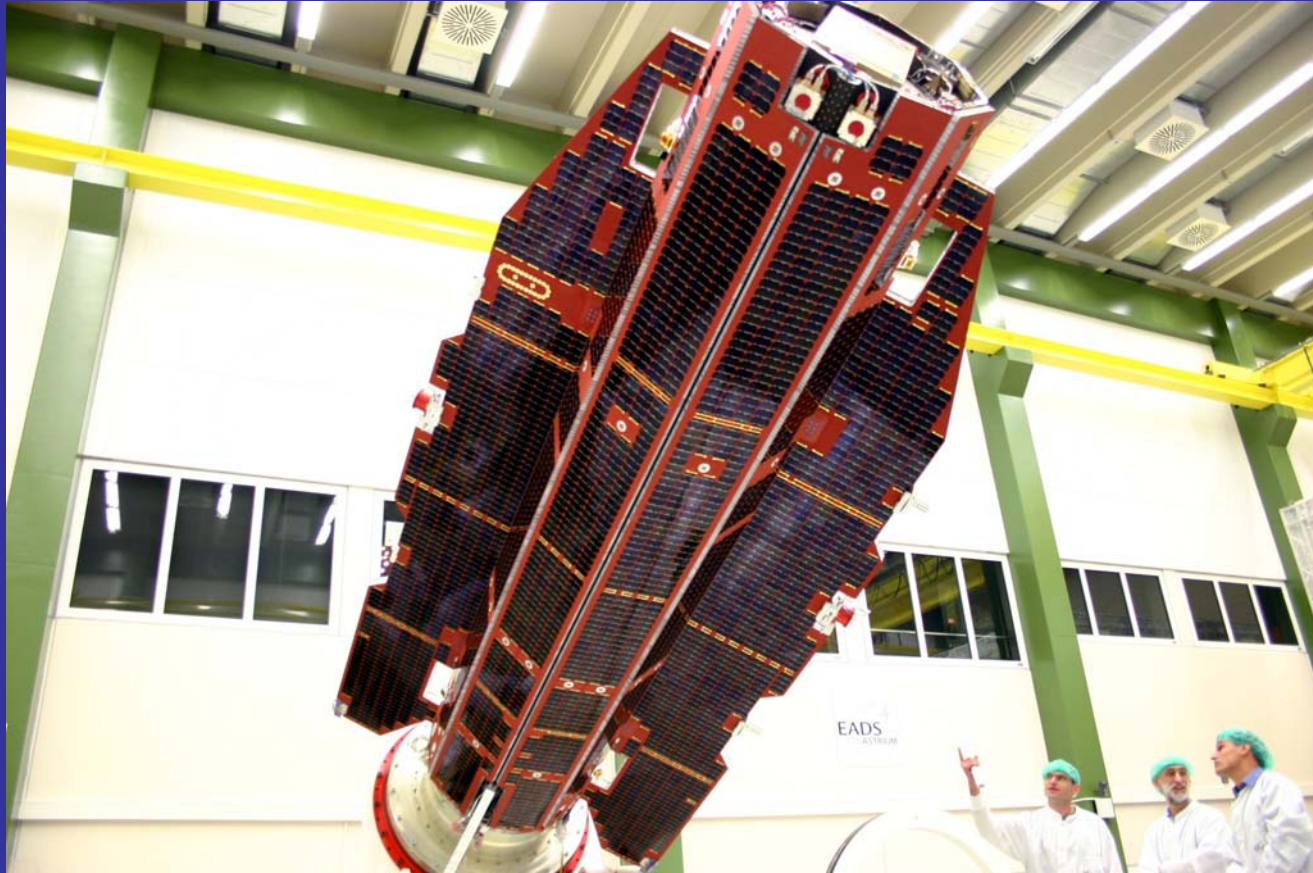

Jakob Flury · Reiner Rummel
Christoph Reigber · Markus Rothacher
Gerd Boedecker · Ulrich Schreiber
Editors

Observation of the Earth System from Space

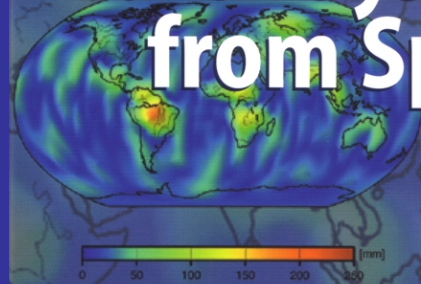

 Springer



Uni Hamburg

Uni Hannover

GFZ Potsdam

Uni Bonn

BKG Frankfurt

U Stuttgart

TU München

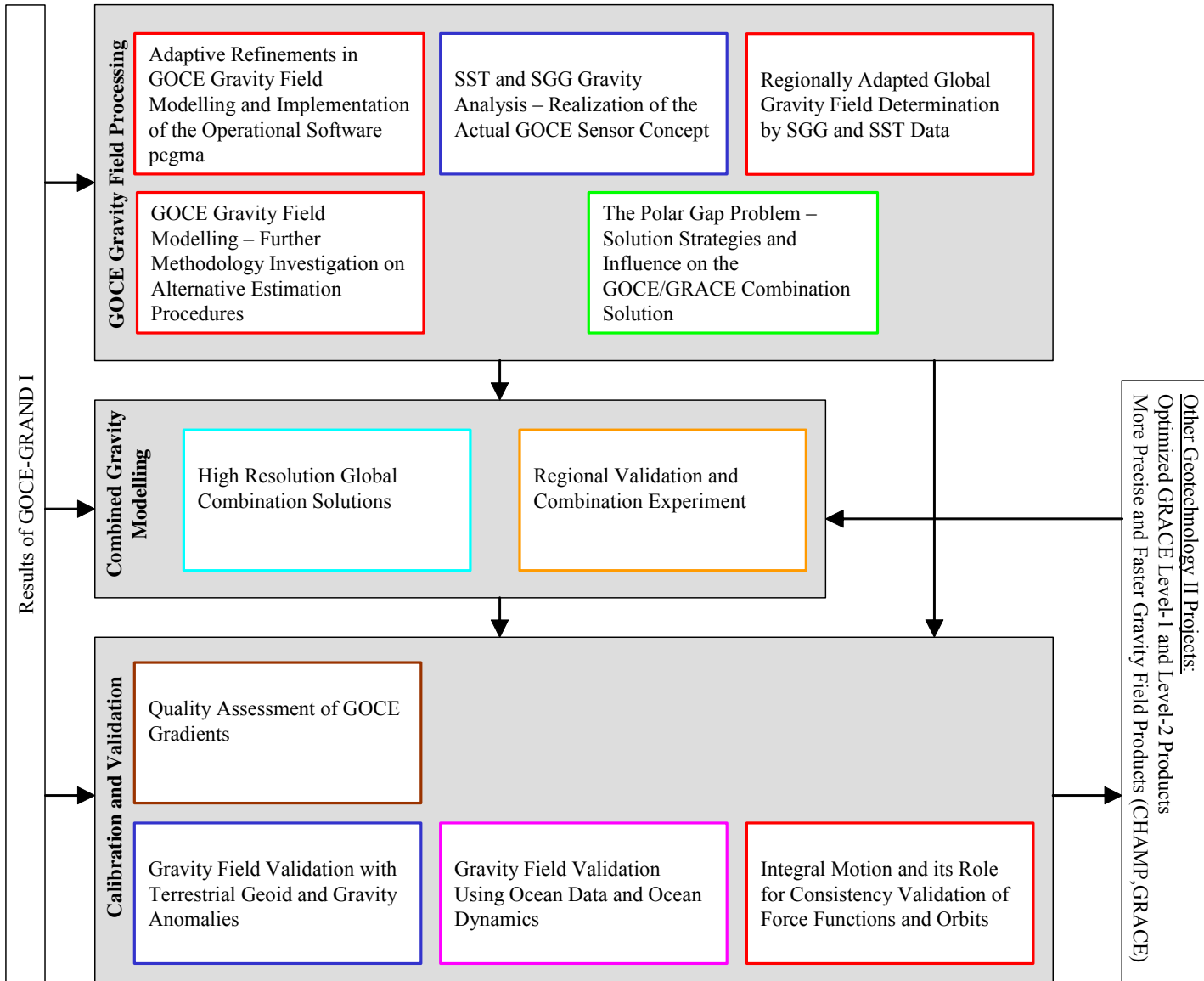

Leistungsdichtespektrum der ZZ-Komponente

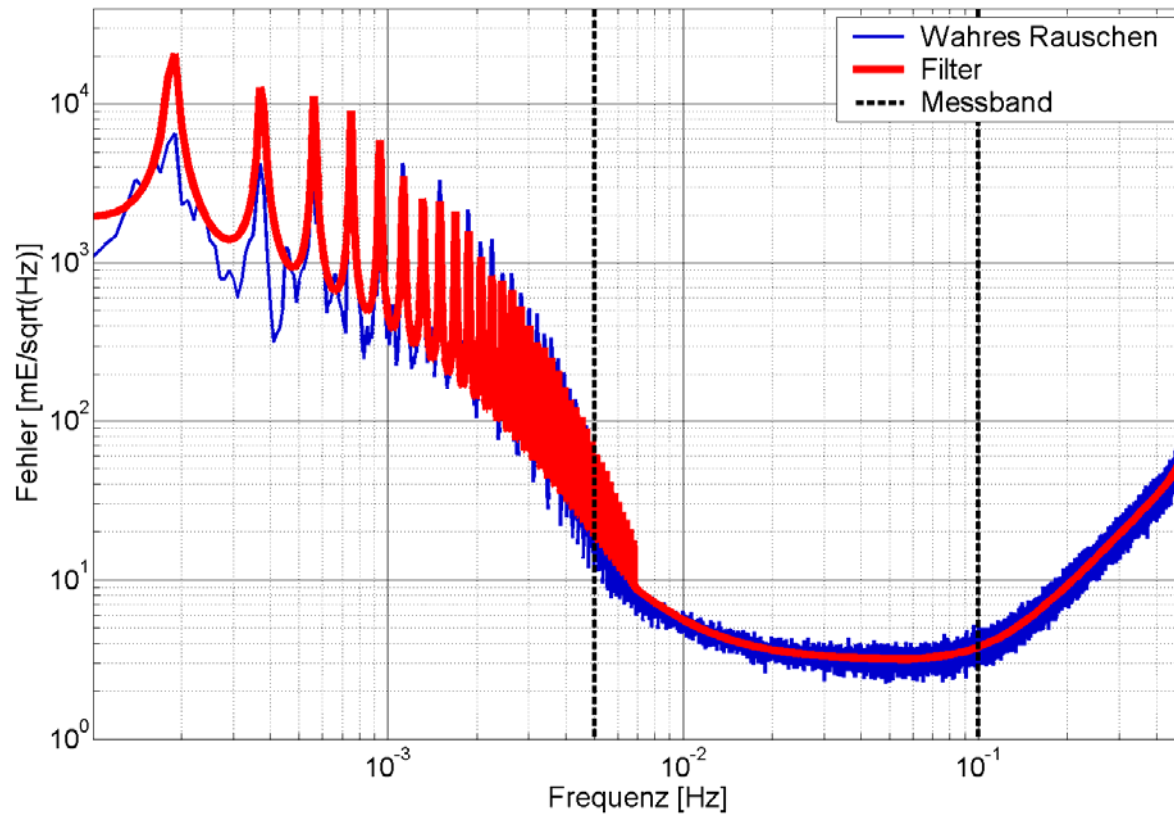

Projektion des Satellitenorbits in die Äquatorebene

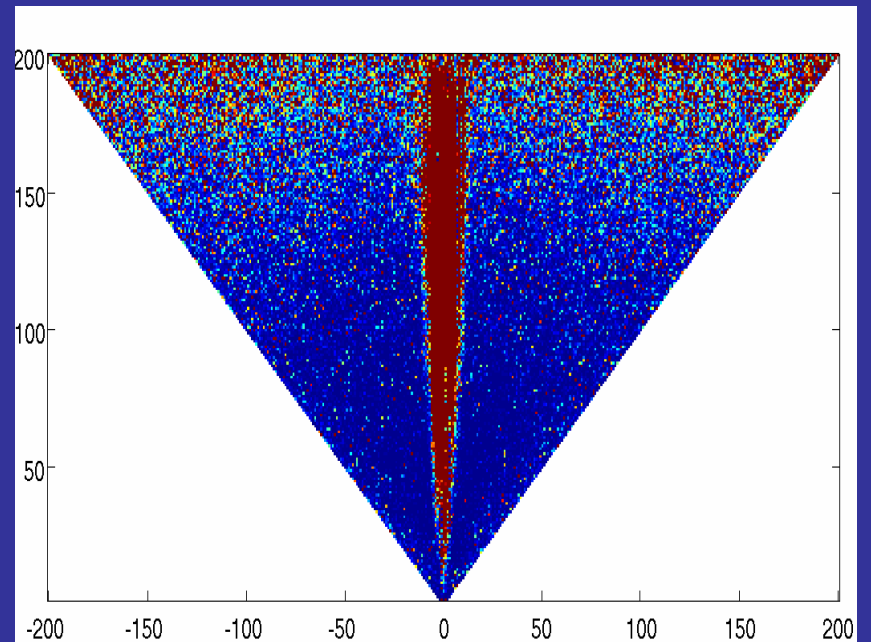
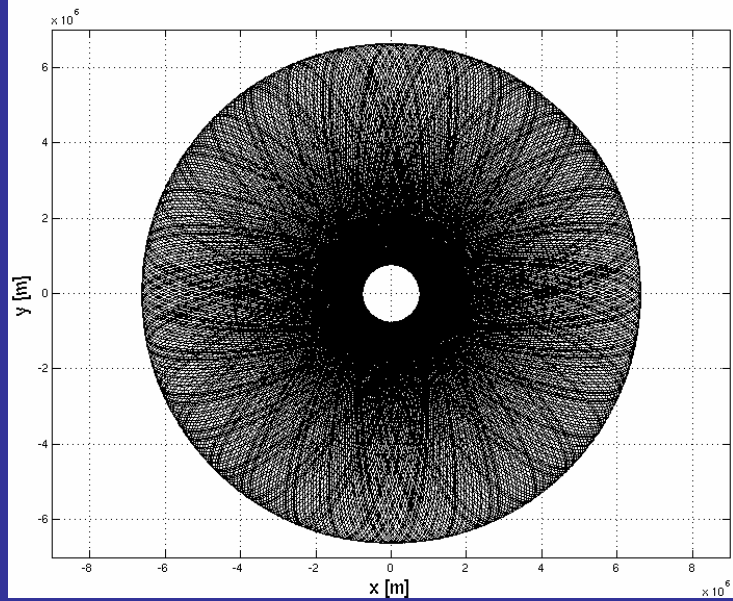

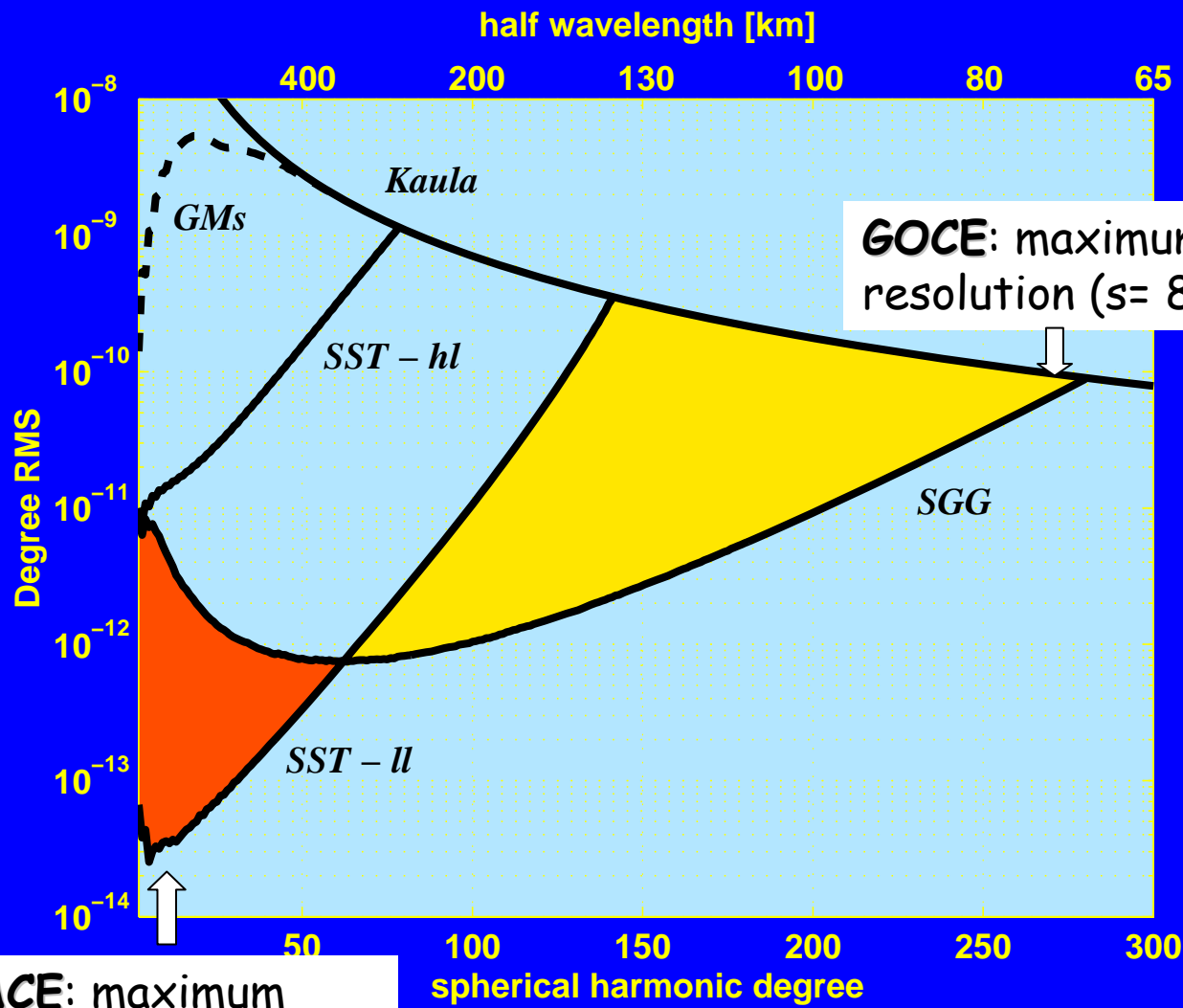

B.G.I. GRAVITY DATA BASE (density per 30'*30')

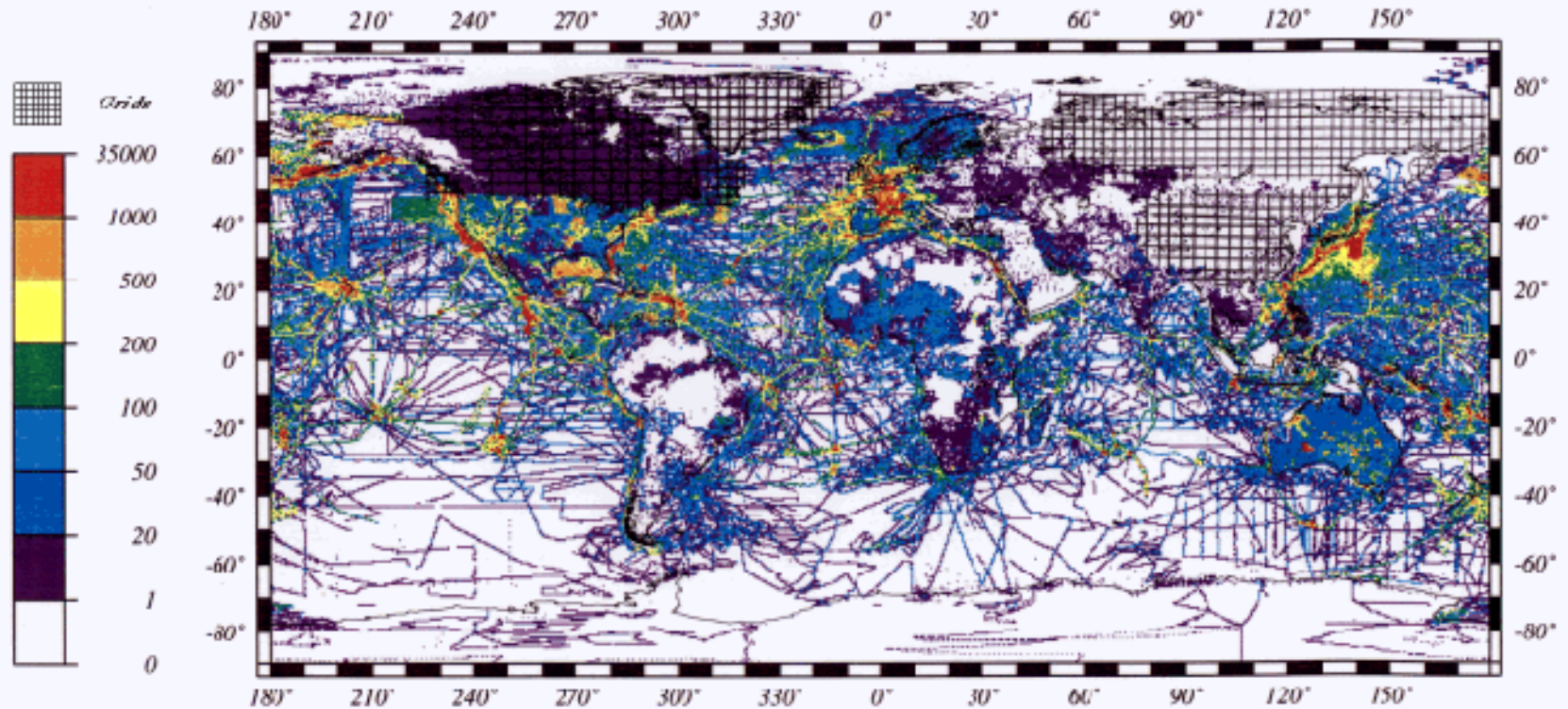

gravity measurements: 12 649 246

10 535 654 marine data & 2 113 592 land data

Calibration and Validation

GOCE

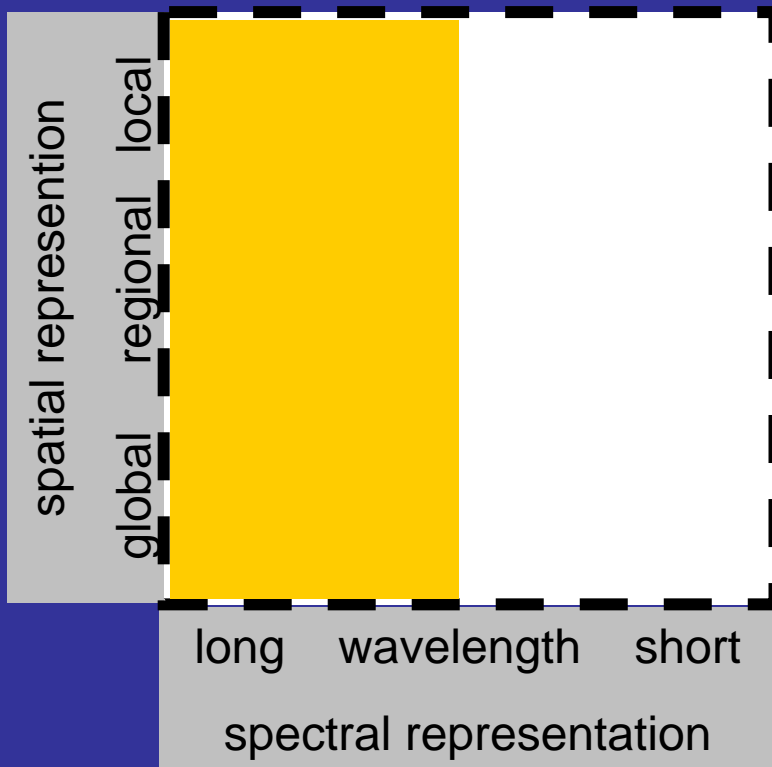

CAL/VAL data sets

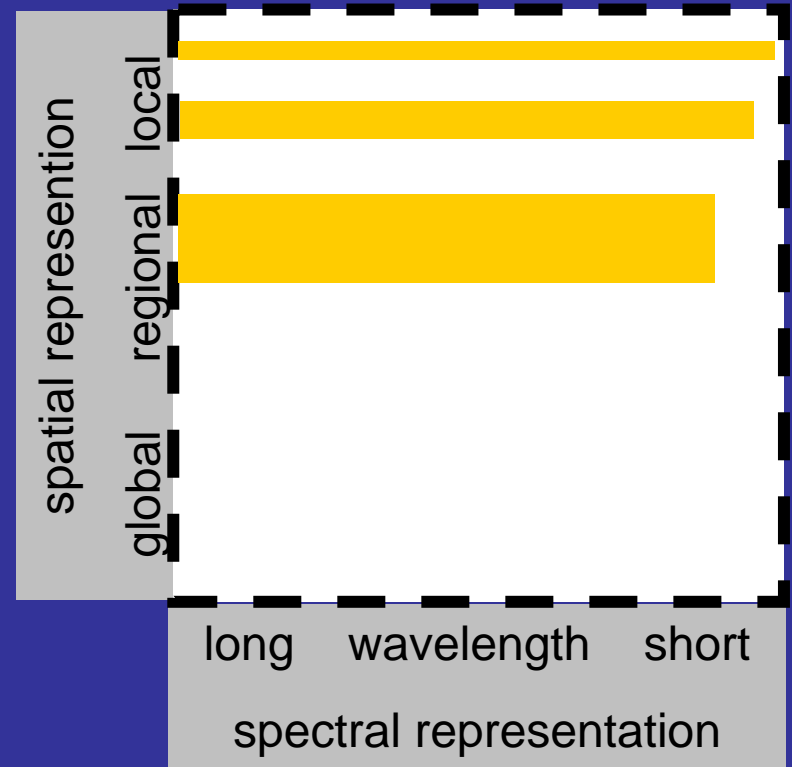

Regional Validation and Combination Experiment

Observations of vertical deflections (courtesy IFE Hannover)

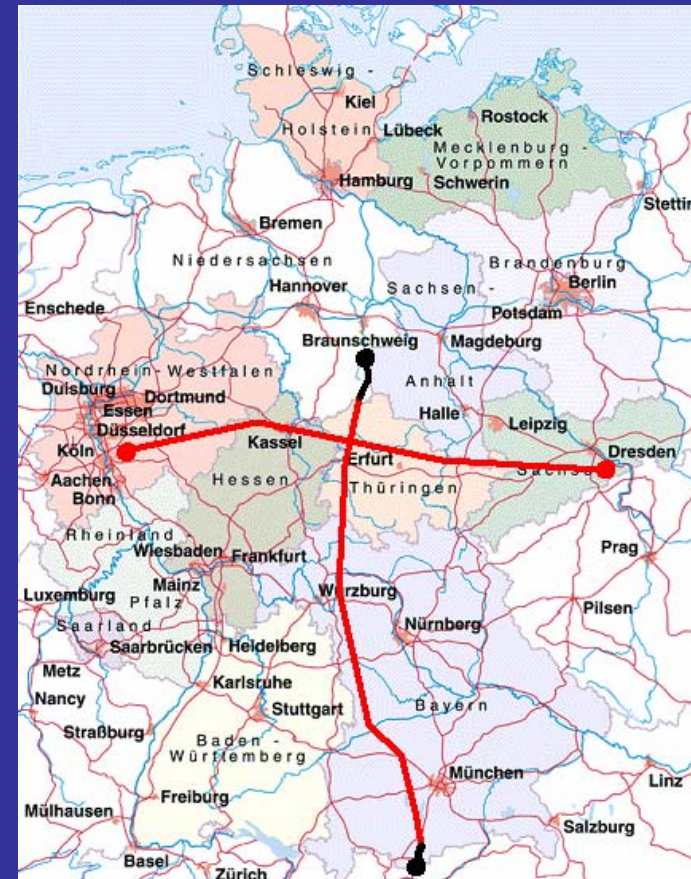
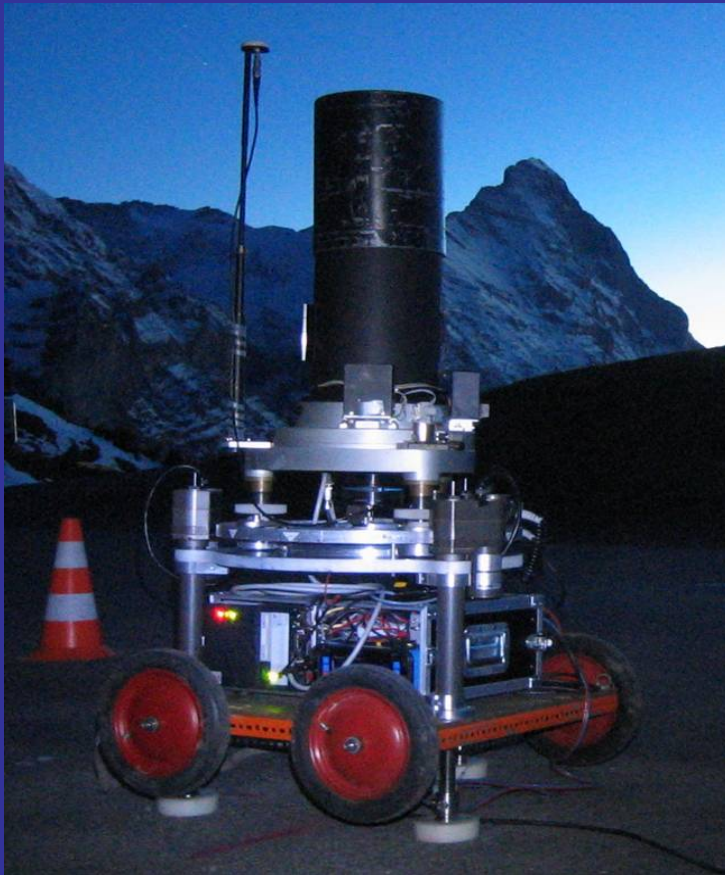

Impulsbilanz

$$M\ddot{\mathbf{R}} - \mathbf{K} = 0$$

Zeitintegration

$$M\dot{\mathbf{R}} - \int_{t_0}^t \mathbf{K} dt = \mathbf{P}_0$$

Impuls = Anfangsimpuls
+ integrierte Kraft

Drehimpulsbilanz

$$M\ddot{\mathbf{R}} - \mathbf{K} = 0$$

vektorielle
Multiplikation mit \mathbf{R}

$$M\mathbf{R} \times \ddot{\mathbf{R}} - \mathbf{R} \times \mathbf{K} = 0$$

Zeitintegration

$$M\mathbf{R} \times \dot{\mathbf{R}} - \int_{t_0}^t \mathbf{R} \times \mathbf{K} dt = \mathbf{L}_0$$

Drehimpuls = Anfangsdrehimpuls
+ integriertes Drehmoment

Energiebilanz

$$M\ddot{\mathbf{R}} - \mathbf{K} = 0$$

skalare
Multiplikation mit $\dot{\mathbf{R}}$



$$M\dot{\mathbf{R}} \cdot \ddot{\mathbf{R}} - \mathbf{K} \cdot \dot{\mathbf{R}} = 0$$

Zeitintegration

$$\frac{1}{2} M\dot{\mathbf{R}}^2 - \int_{t_0}^t \mathbf{K} \cdot \dot{\mathbf{R}} dt = E$$

Energie = kinetische Energie
- integrierte Arbeit

GOCE-GRAND-2 Working Groups

<p>GOCE Standards</p>	<p>System Transformations; Geometrical Models; Dynamical Models.</p>	
<p>GOCE and Surface Data</p>	<p>Combination & Validation; Corrections to be applied; Data Weighting; Aliasing & Filtering Techniques.</p>	
<p>GOCE and Applications</p>	<p>Identification of Needs; Zero Potential; Derived Gravity Field Quantities on Ellipsoid or Earth Surface.</p>	

GOCE ground segment

level 0

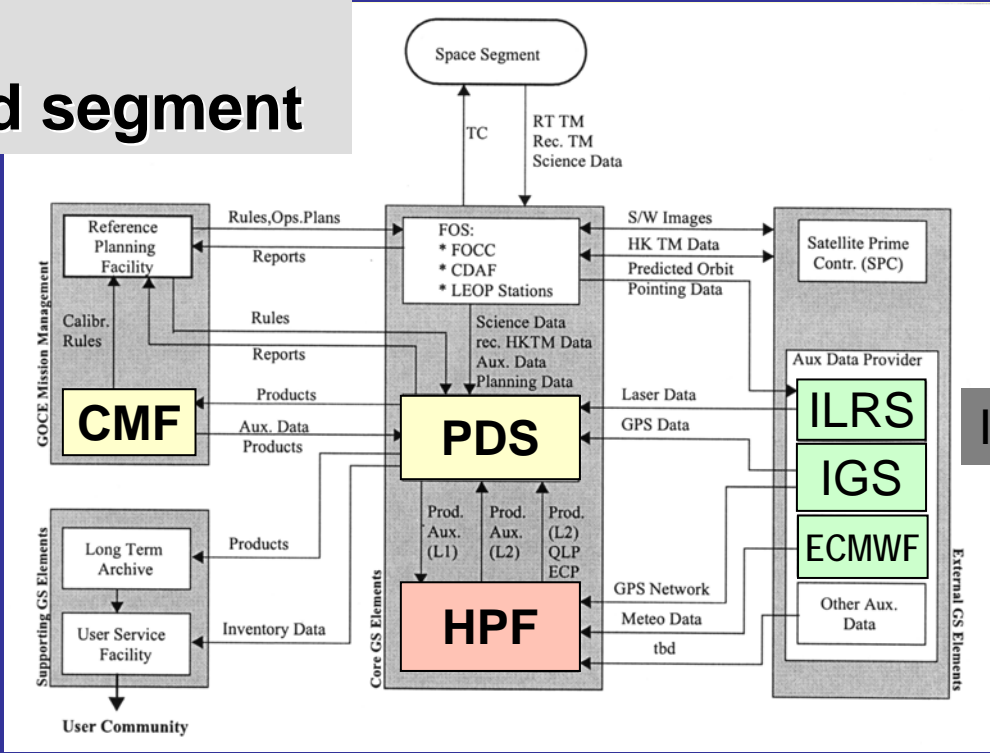

level 1a/1b

level 2

GOCE Cal/Val Team

GOCE User Toolbox

GOCE Application Studies

GOCE Users

level 3

GOCE ground segment

level 0

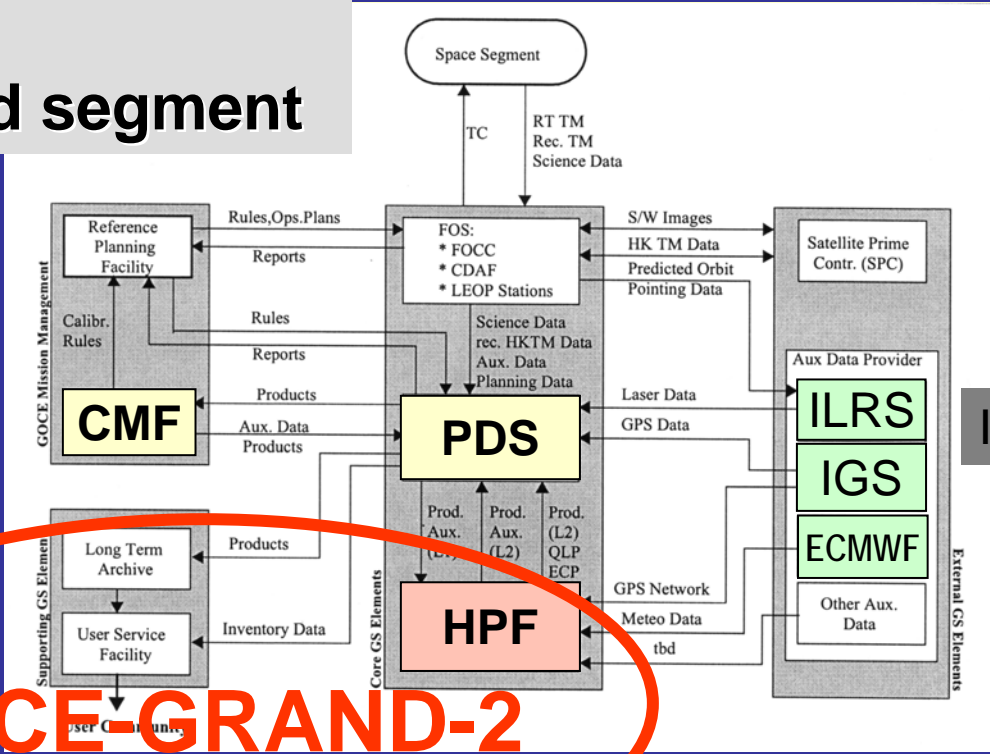

level 1a/1b

level 2

GOCE Cal/Val Team

GOCE-GRAND-2

GOCE User Toolbox

GOCE Application Studies

GOCE Users

level 3

The GRAND Picture

Embedding of GOCE-GRAND-2

- ➔ Participation in ESA GOCE processing (ESA contracts):
PDS, HPF, CMF, CAL/VAL, GUTs, other studies
- ➔ Connection to GT Themes 2 of „Observation of Earth System from Space“
- ➔ Participation in DFG Priority Programme 1257
„Mass Transport and Mass Distribution in System Earth“
- ➔ Involvement in IAG Pilot Project: GGOS
(will belong to IGOS and GEO)

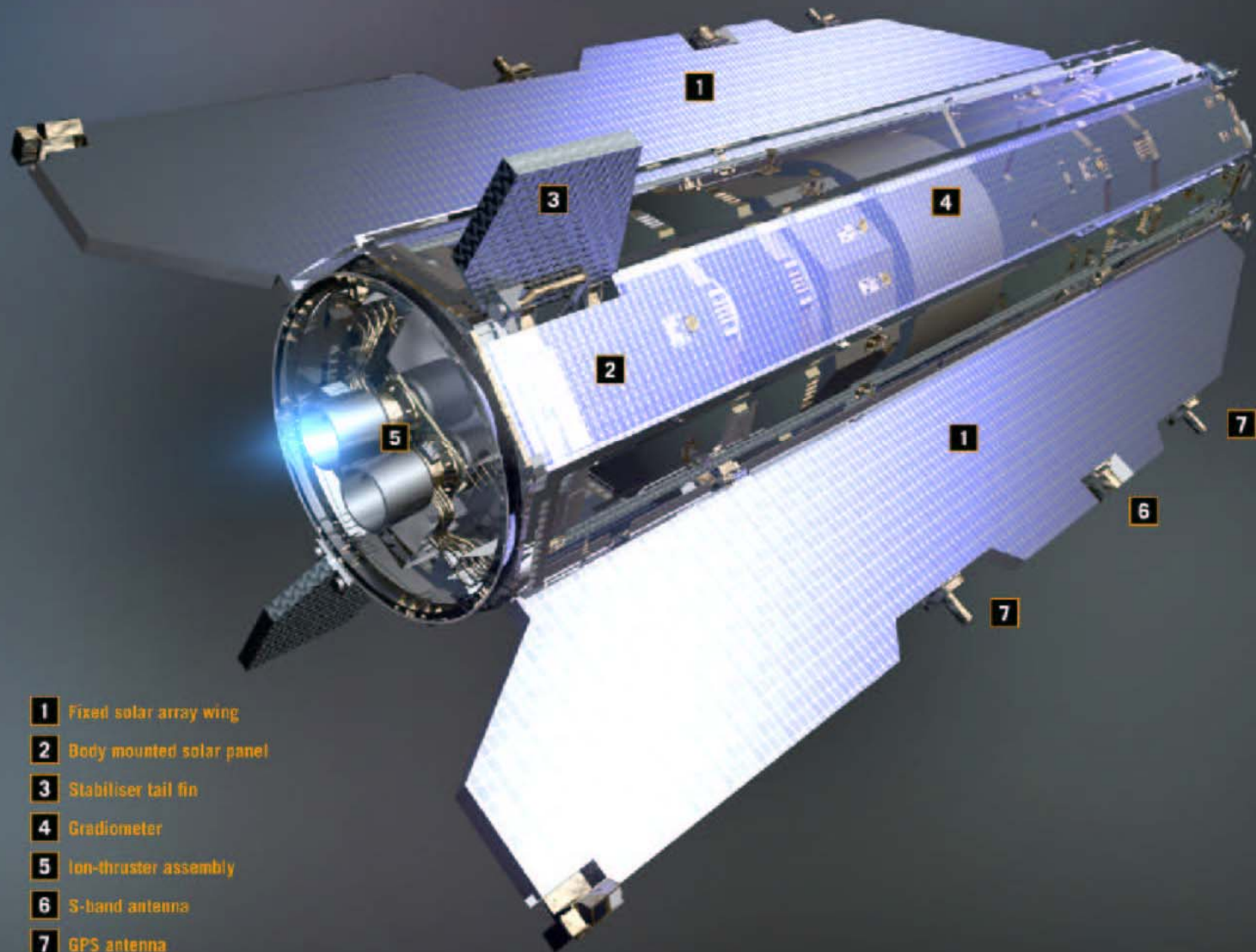

- 1** Fixed solar array wing
- 2** Body mounted solar panel
- 3** Stabiliser tail fin
- 4** Gradiometer
- 5** Ion-thruster assembly
- 6** S-band antenna
- 7** GPS antenna