Synergies between VLBI and GNSS

Urs Hugentobler, Ralf Schmid

Forschungseinrichtung Satellitengeodäsie (FESG)
Institute for Astronomical and Physical Geodesy
Technical University of Munich

5th IVS General Meeting
Measuring the Future
Sankt Petersburg, Russia
March 3, 2008

Synergies between VLBI and GNSS

- Earth rotation parameters
- Troposphere parameters
- Clock parameters



Introduction

- VLBI and GNSS are in some respect very **similar** ...
 - both are one-way measurement systems
 - synchronization of distant clocks required
 - operating in the microwave range of the electromagnetic spectrum
 - affected by tropospheric refraction in the same way
 - correlation of weak signals
 - measurement of code and phase ...
- ... and in some respect very **different**
 - observed objects
 - very different antenna effects
 - correlation of unknown signals vs. correlation of known signals
 - access to kinematic non-rotating system vs. dynamical realization
 - expensive vs. cheap instrumentation and operation

Subdaily Earth Rotation Parameters with GNSS

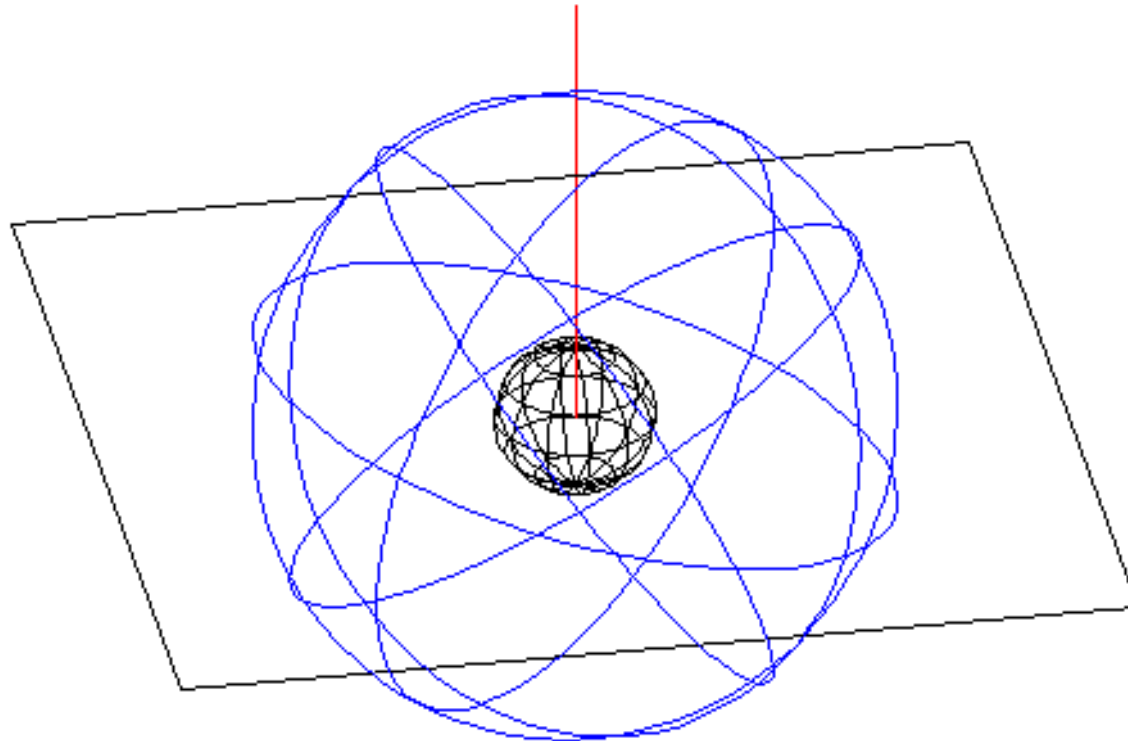

Subdaily Earth Rotation Parameters with GNSS

- Rotation of orbit constellation

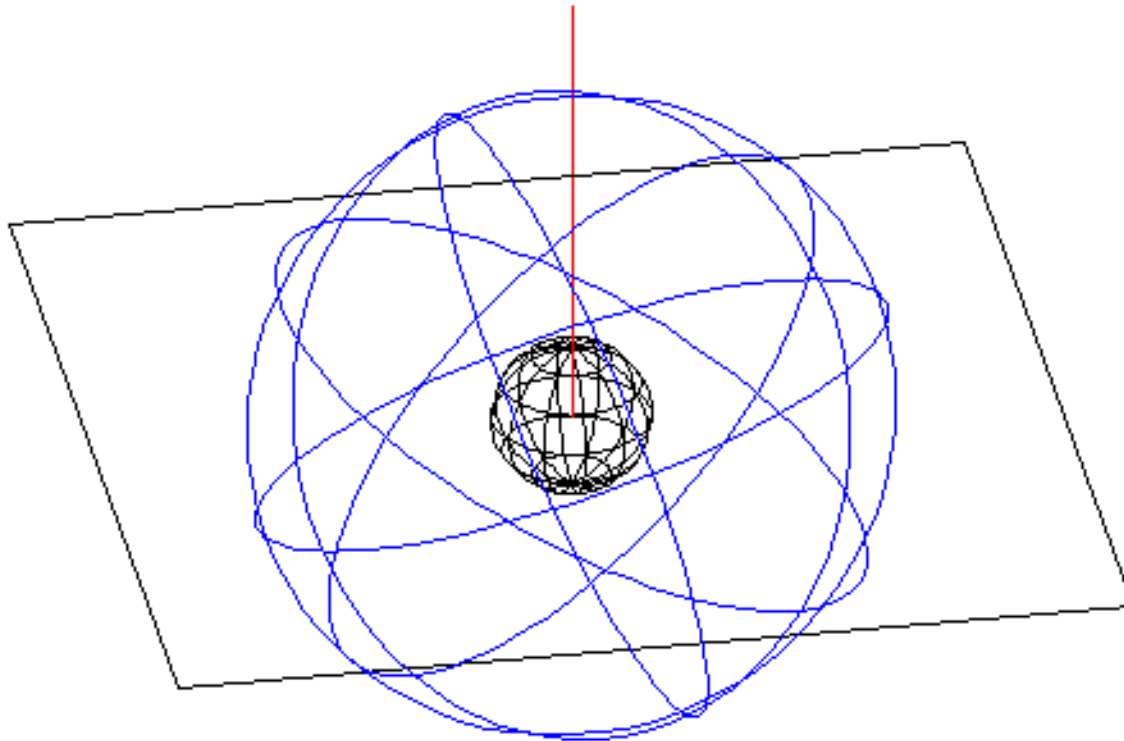

Subdaily Earth Rotation Parameters with GNSS

- Compensated by corresponding rotation of the station network

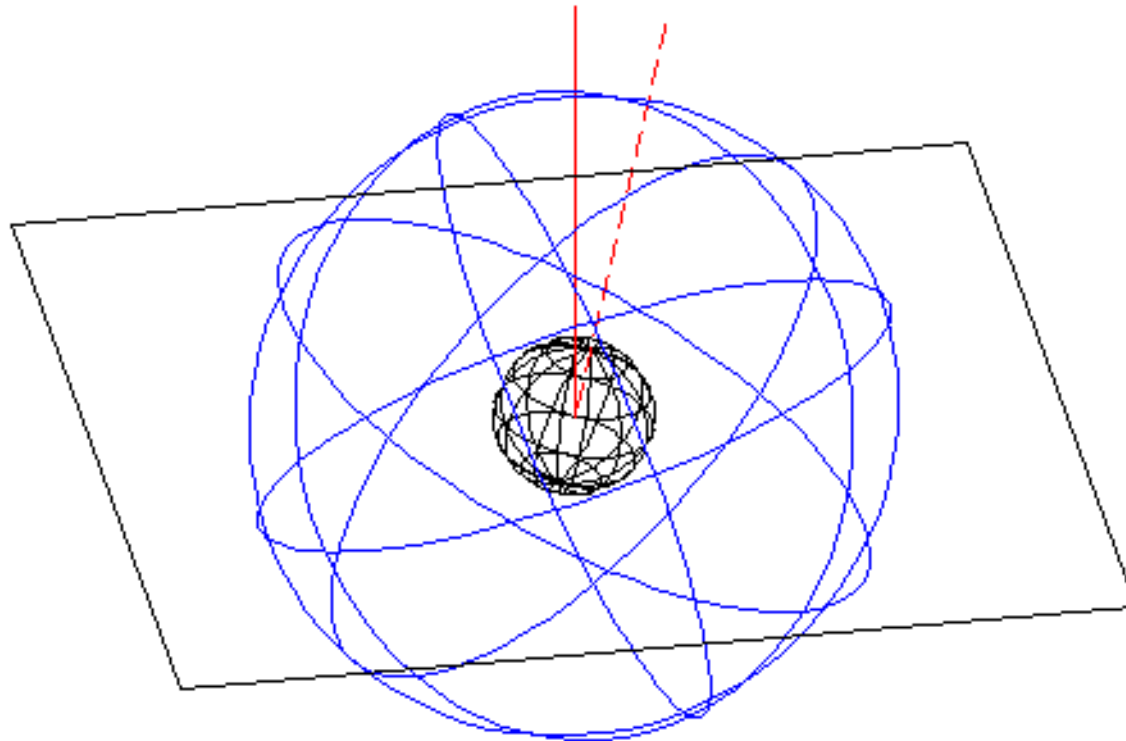

Subdaily Earth Rotation Parameters with GNSS

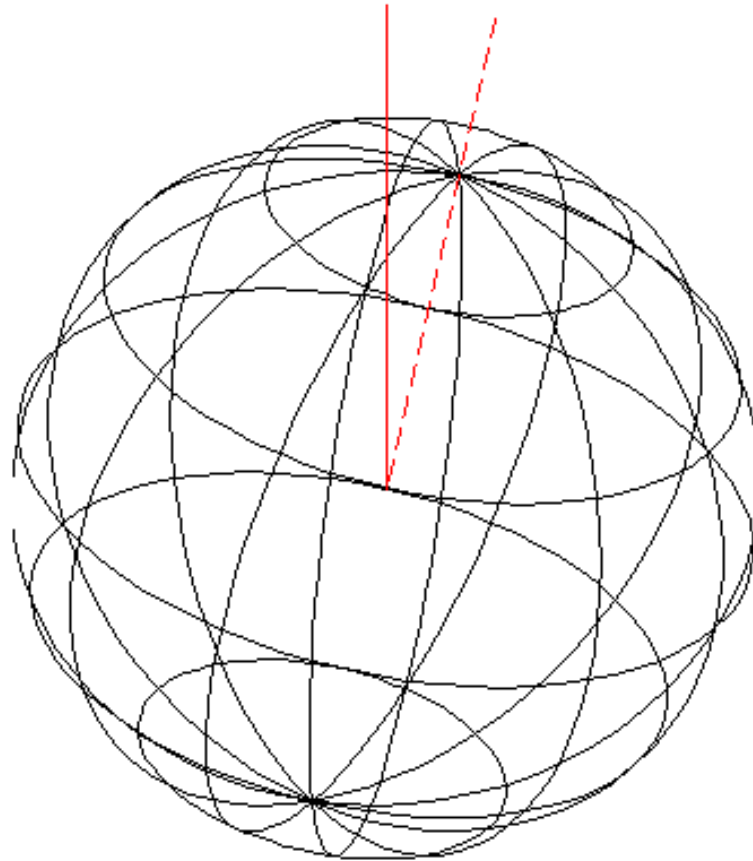

Subdaily Earth Rotation Parameters with GNSS

- Daily retrograde rotation of pole

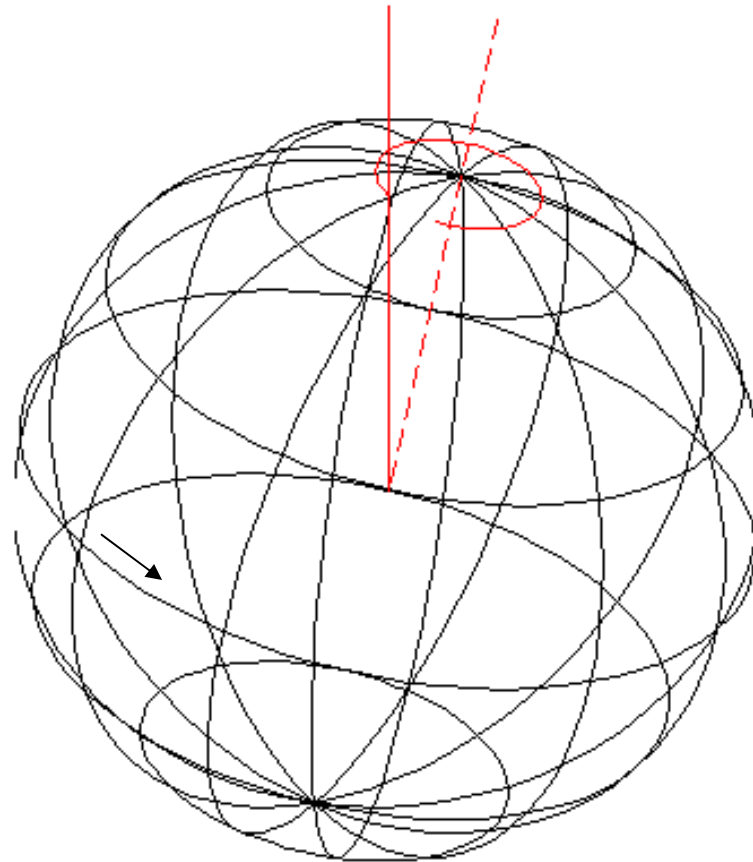

Subdaily Earth Rotation Parameters with GNSS

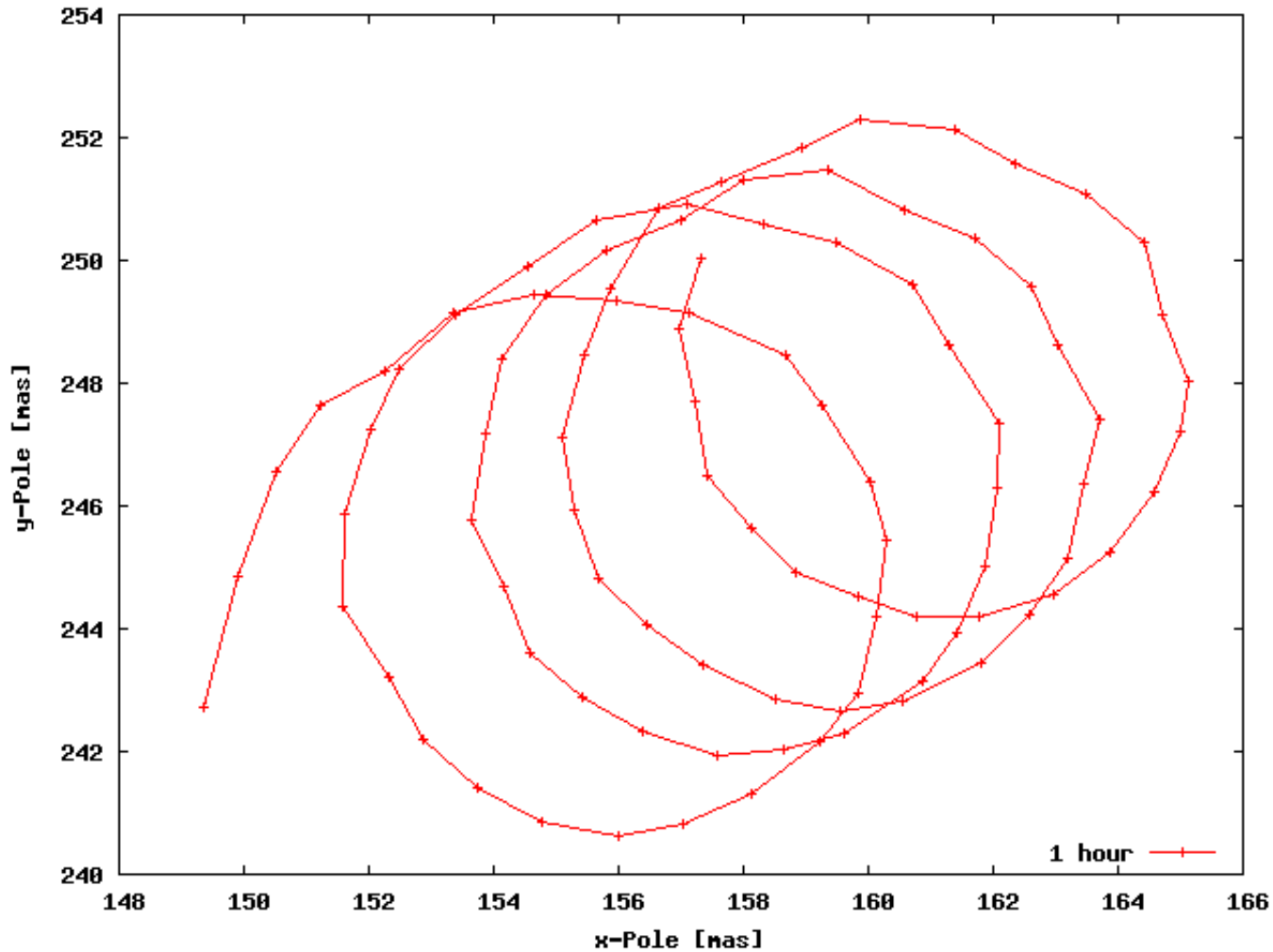

Troposphere Parameters, Zenith Delays

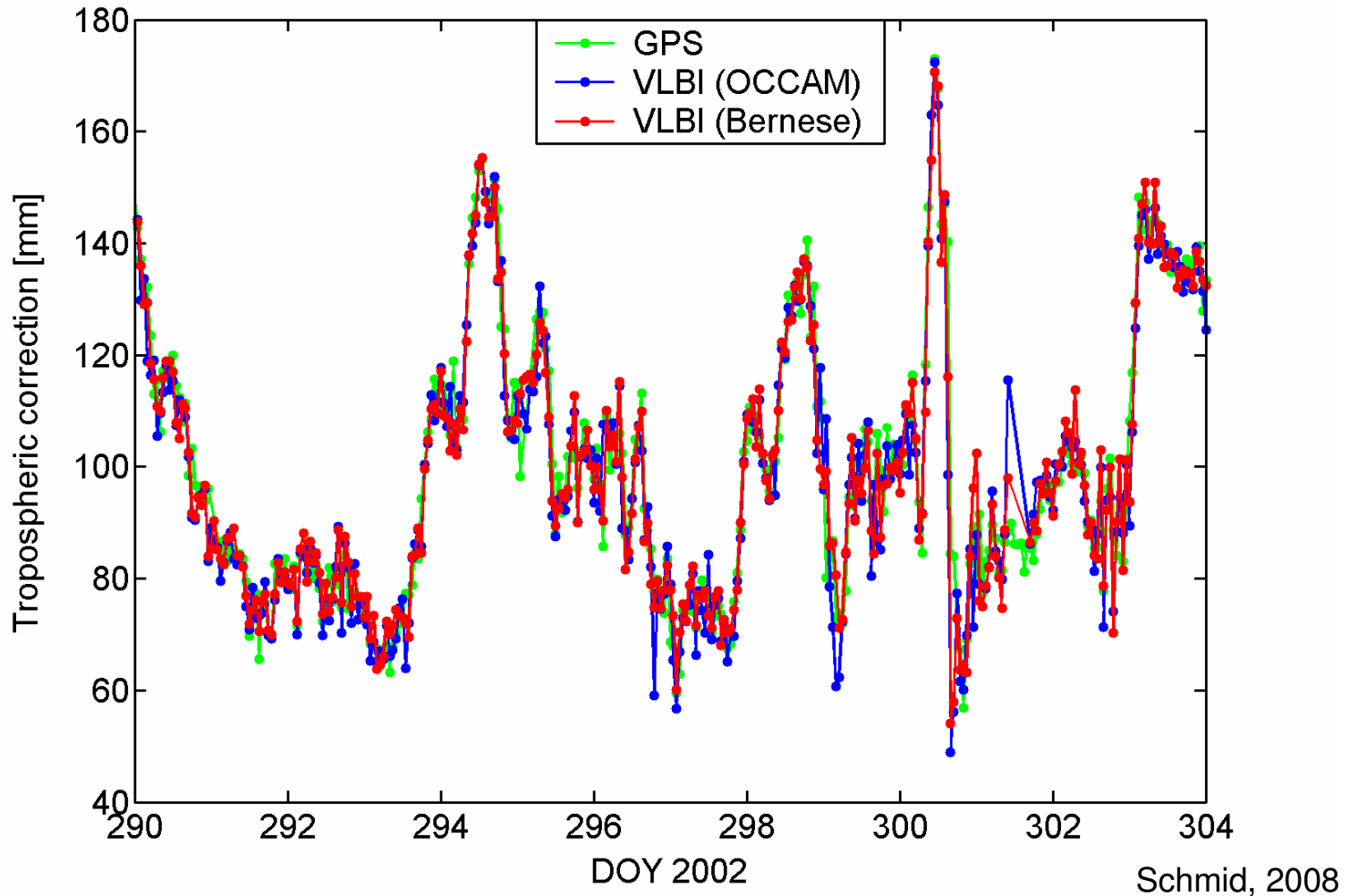

Troposphere Parameters, Gradients

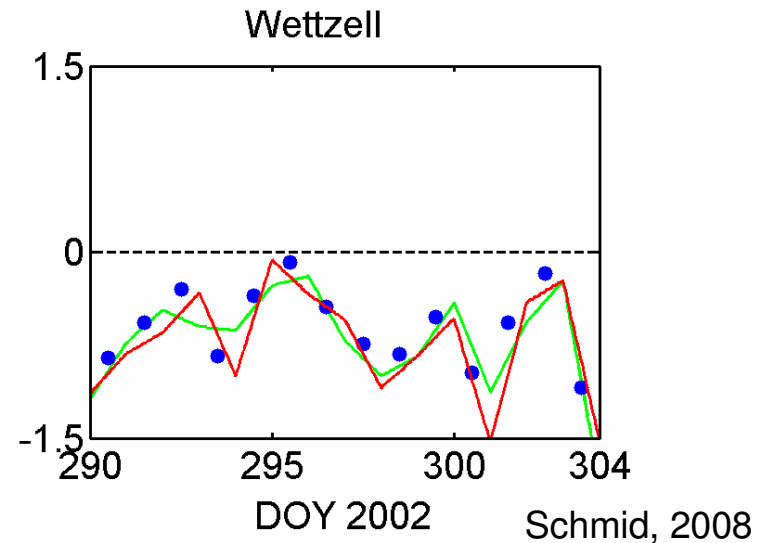
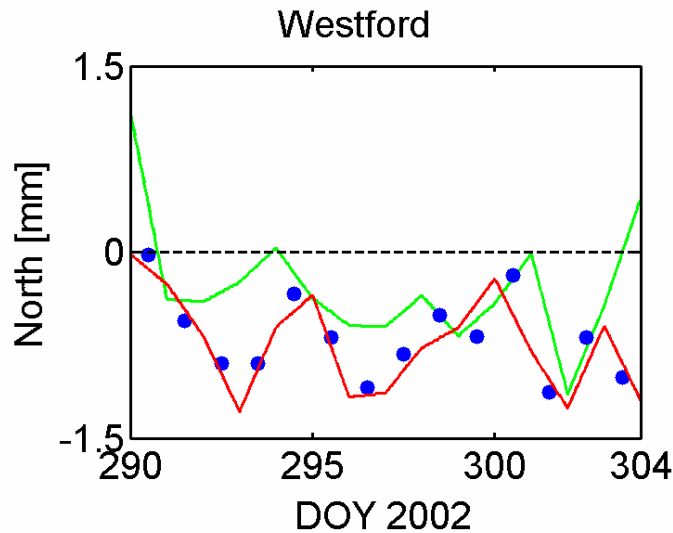
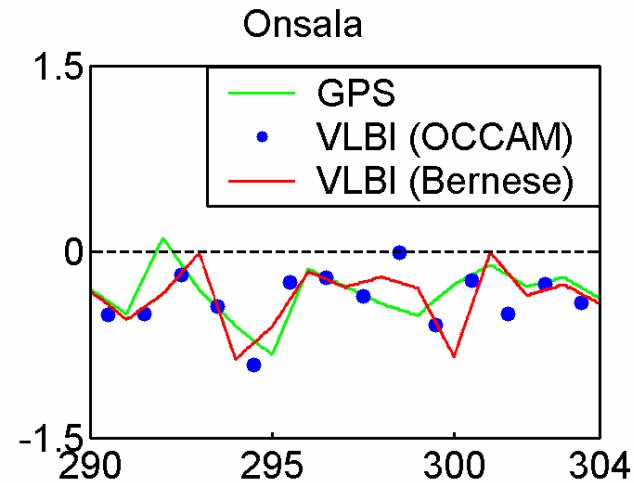
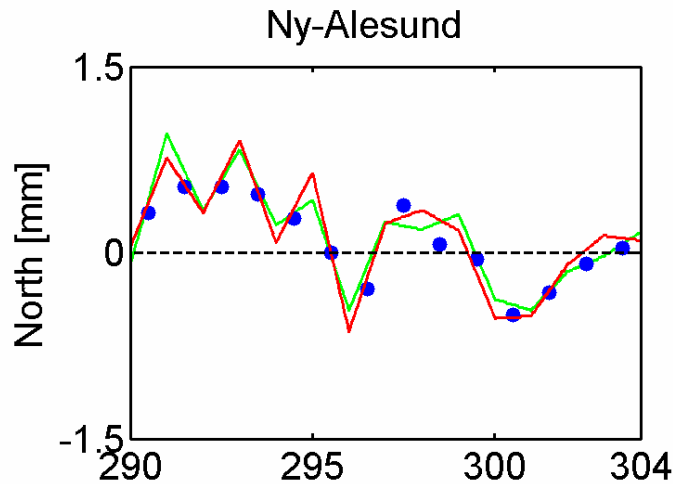

Clock Parameters

- VLBI
 - ground clock synchronization required
 - H-maser provides stability of frequency during scan
 - clock model connects scans through a session
 - usually low degree polynomial

- GNSS
 - space and ground clock synchronization required
 - Cs or Rb clocks in satellites, stability 10^{-13} – 10^{-14}
 - receivers with internal quartz or connected to external frequency standard (e.g. H-maser at VLBI stations)
 - no clock modeling, epoch-wise estimation of clock parameters
 - pseudorange+carrier phase: clock comparison at sub-ns level
 - phase-only: frequency comparison at 10-ps level

Clock Parameter Estimation with GPS

- Clock estimation for regional GPS network

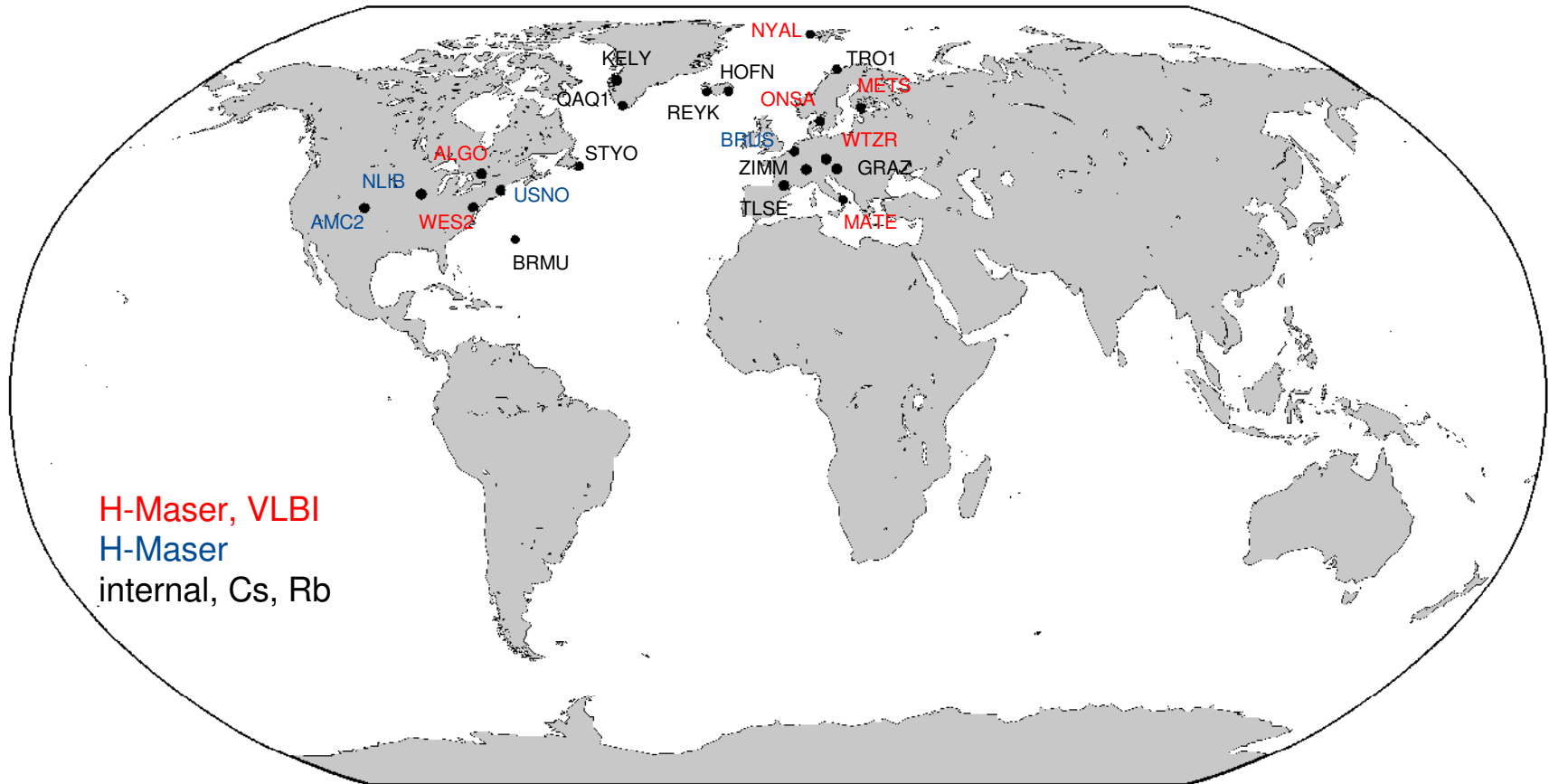

Clock Parameter Estimation with GPS

- Precise Point Positioning (PPP)
 - very efficient
 - relies on precise IGS orbits and clocks
 - use of pseudorange and carrier phase
 - accuracy at ns-level
 - Bernese GPS Software V 5.0

Clock Parameter Estimation with GPS

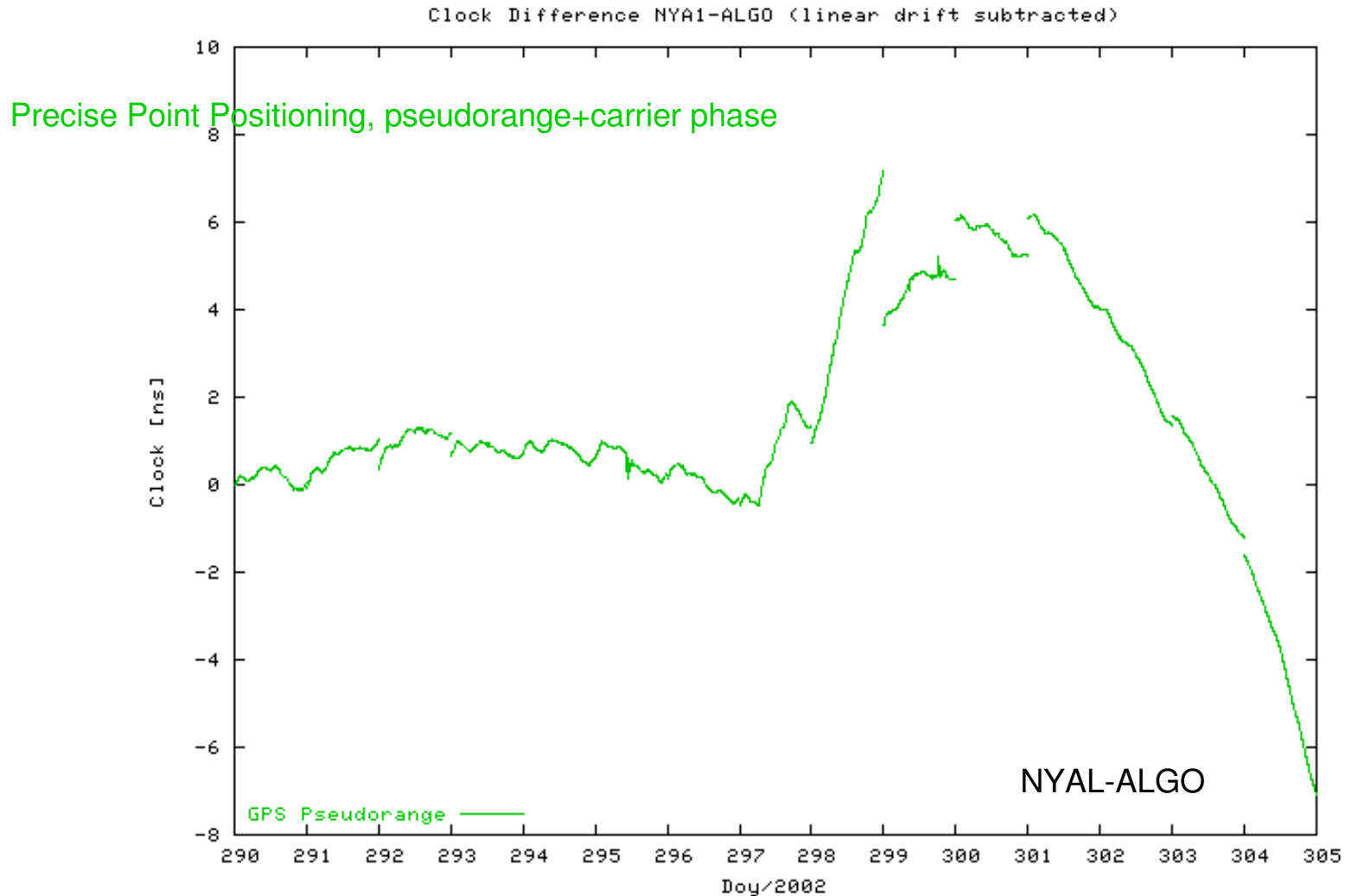

Clock Parameter Estimation with GPS

- Precise Point Positioning (PPP)
 - very efficient
 - relies on precise IGS orbits and clocks
 - use of pseudorange and carrier phase
 - accuracy at ns-level

- Phase-only network solution
 - analysis of daily RINEX files, including 24h epoch
 - concatenation of daily clock time series
 - arbitrary offset due to ambiguities
 - precision level at 10 ps level

Clock Parameter Estimation with GPS

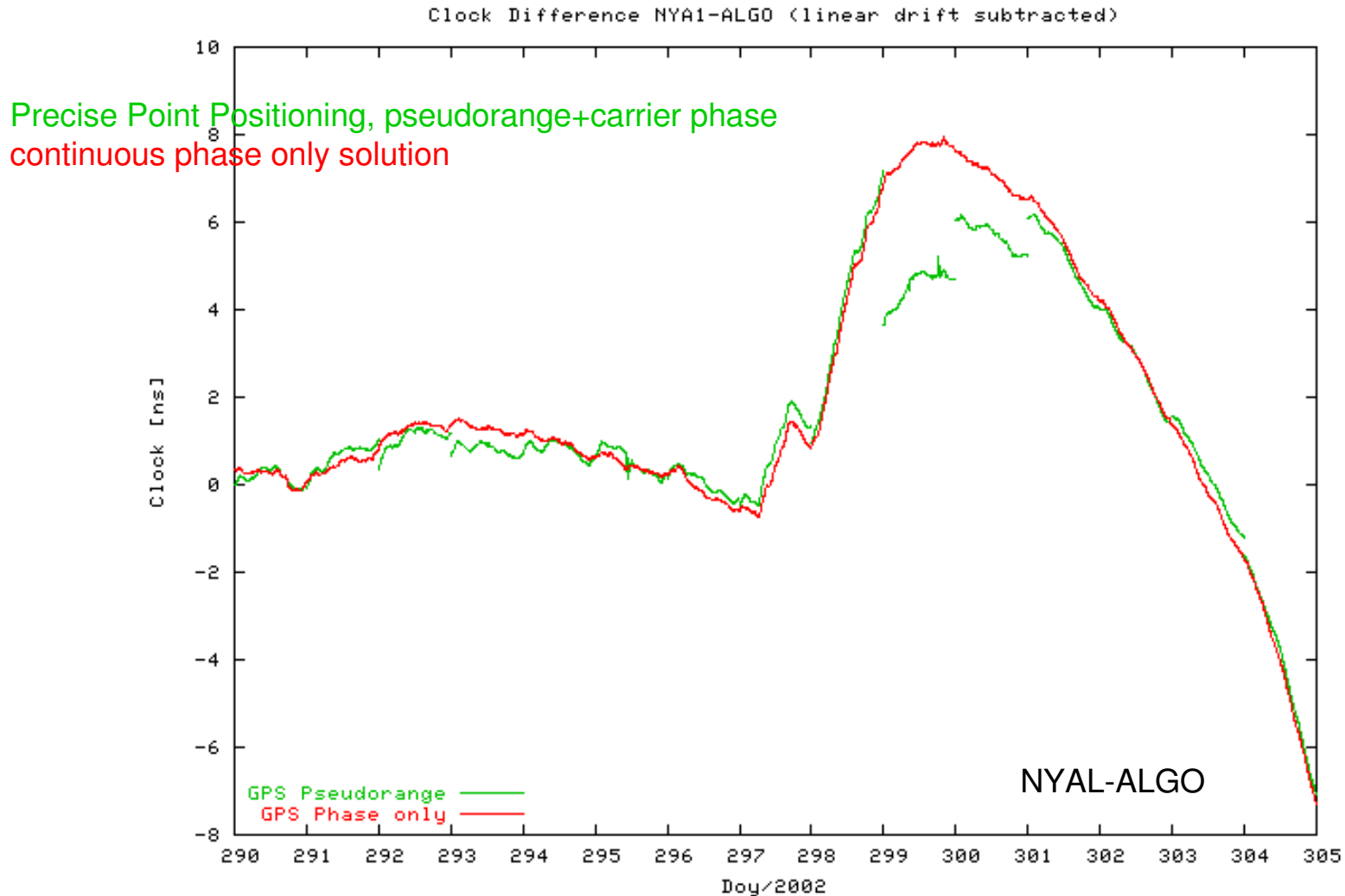

Clock Parameter Estimation, Comparison with VLBI

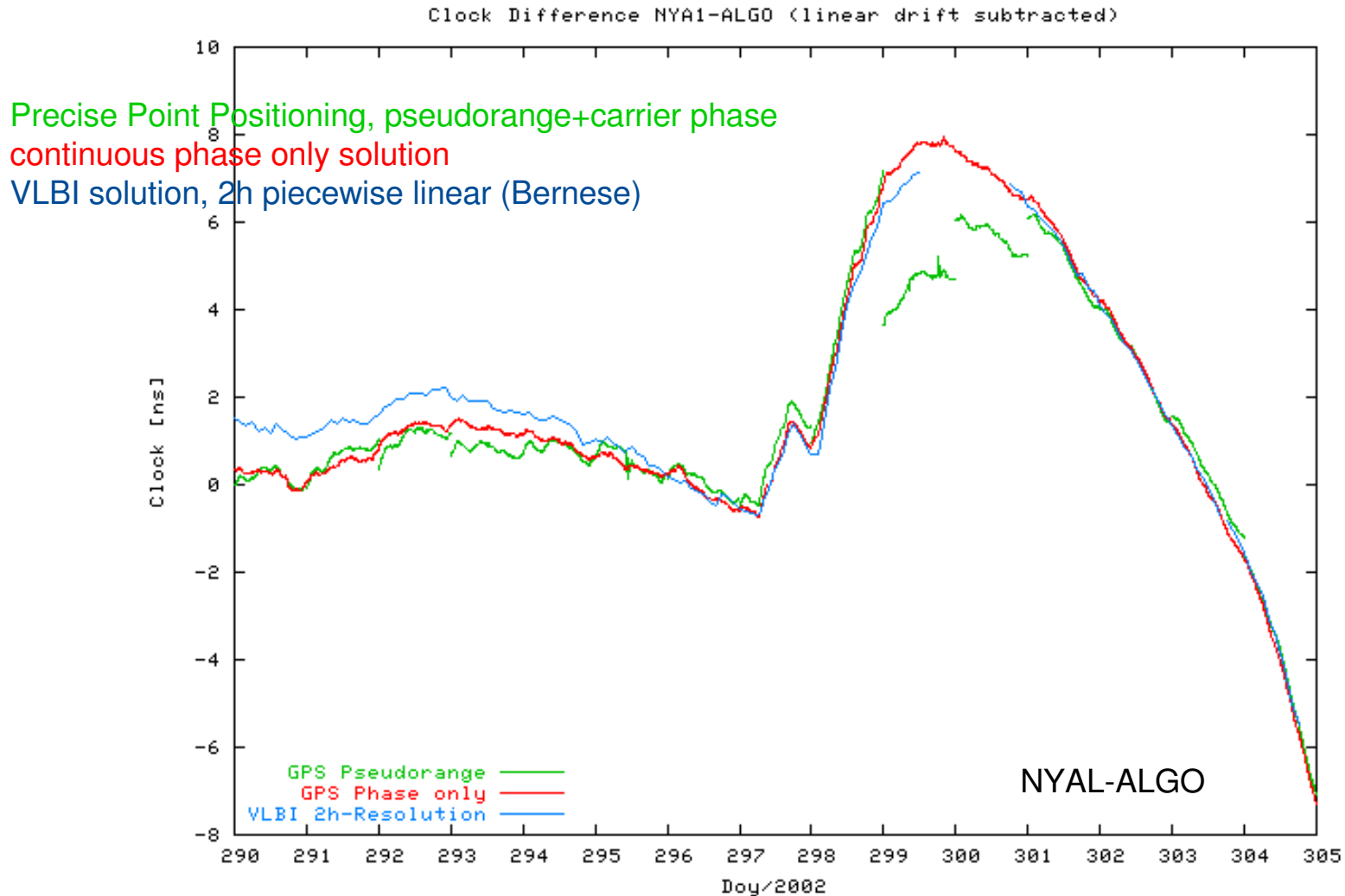

Clock Parameter Estimation, Comparison with VLBI

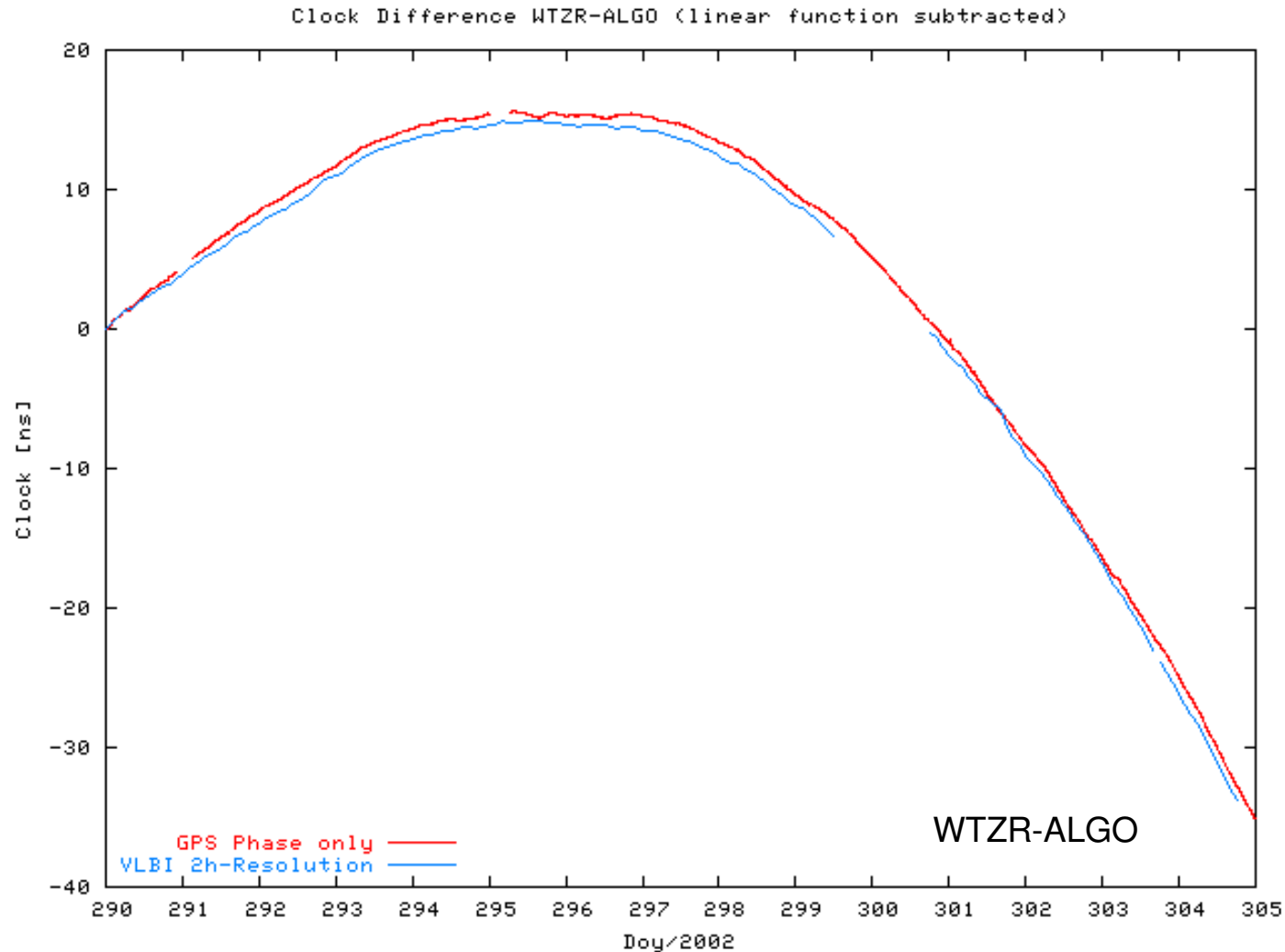

Clock Parameter Estimation, Comparison with VLBI

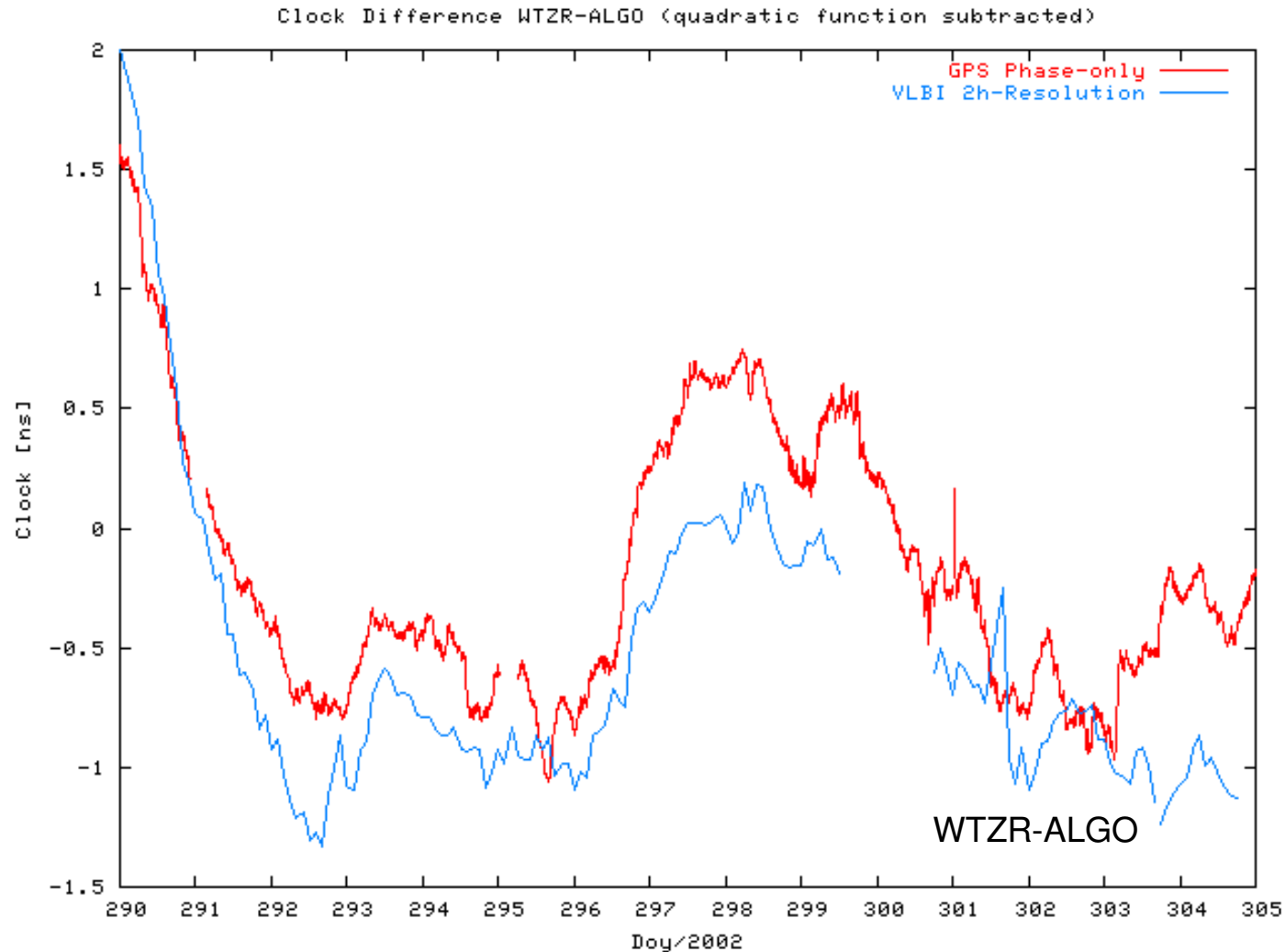

Clock Parameter Estimation with GPS

- Continuous GPS phase solution, comparison with TWSTFT

Phase solution, phase solution, TWSTFT solution

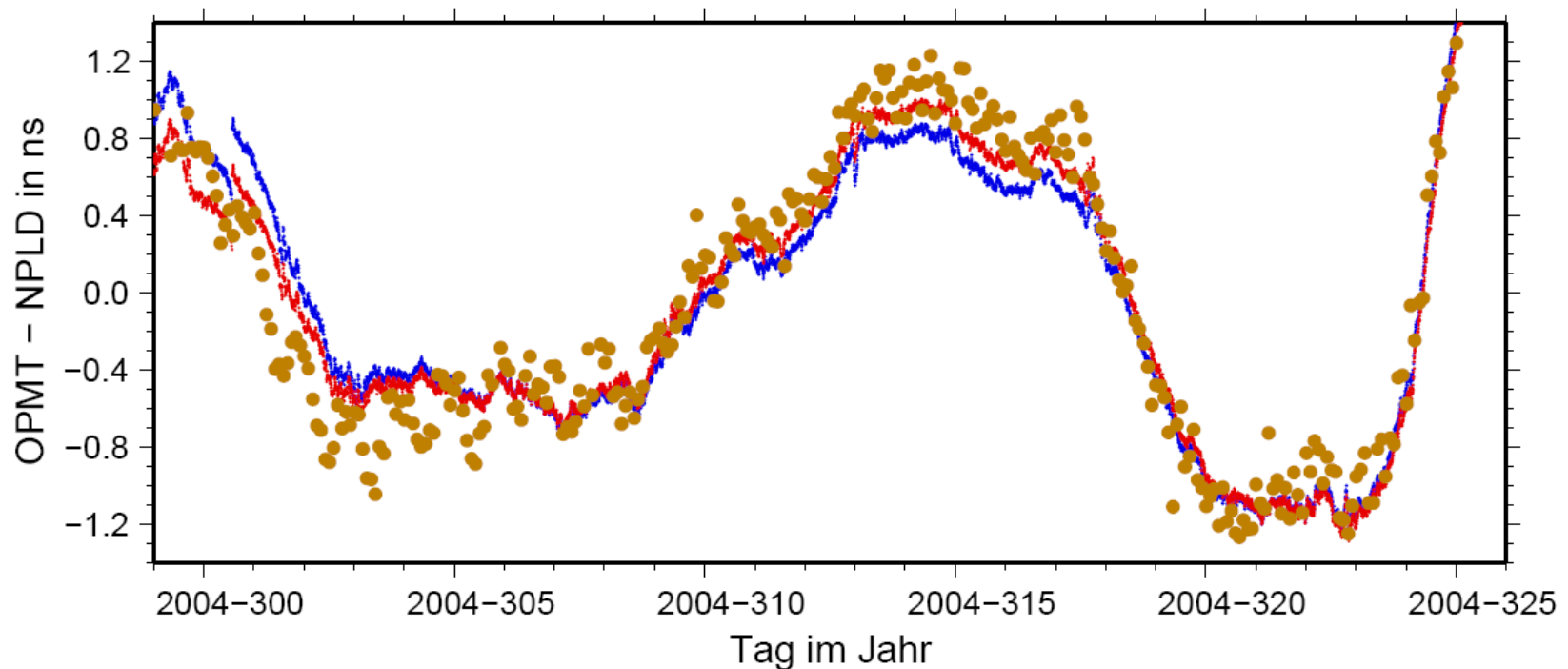

Dach 2005

Clock Parameter Estimation with GPS

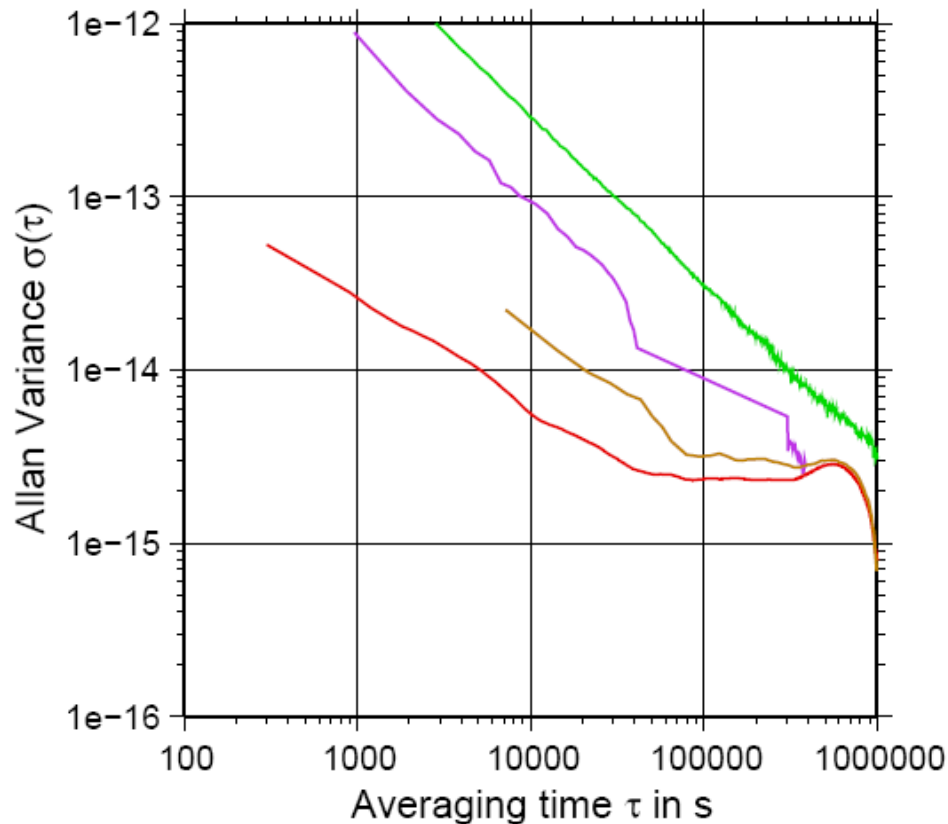

epochwise pseudorange solution

GPS P3 solution

continuous phase-only solution

TWSTFT solution

Dach 2005

Clock Parameter Estimation with GPS

- Synergies for VLBI
 - Constraining to variations of phase only solution for intervals above ca. 1 hour
 - Identification of clock problems on baselines
- Synergies for GPS
 - Use of H-Maser as external clock
 - Modeling of clock over short time intervals instead of epoch-wise estimation of clocks

Drift of Phase wrt. Code

Continuous **phase-only** and **code+phase** solutions

baseline PTBB→NISU

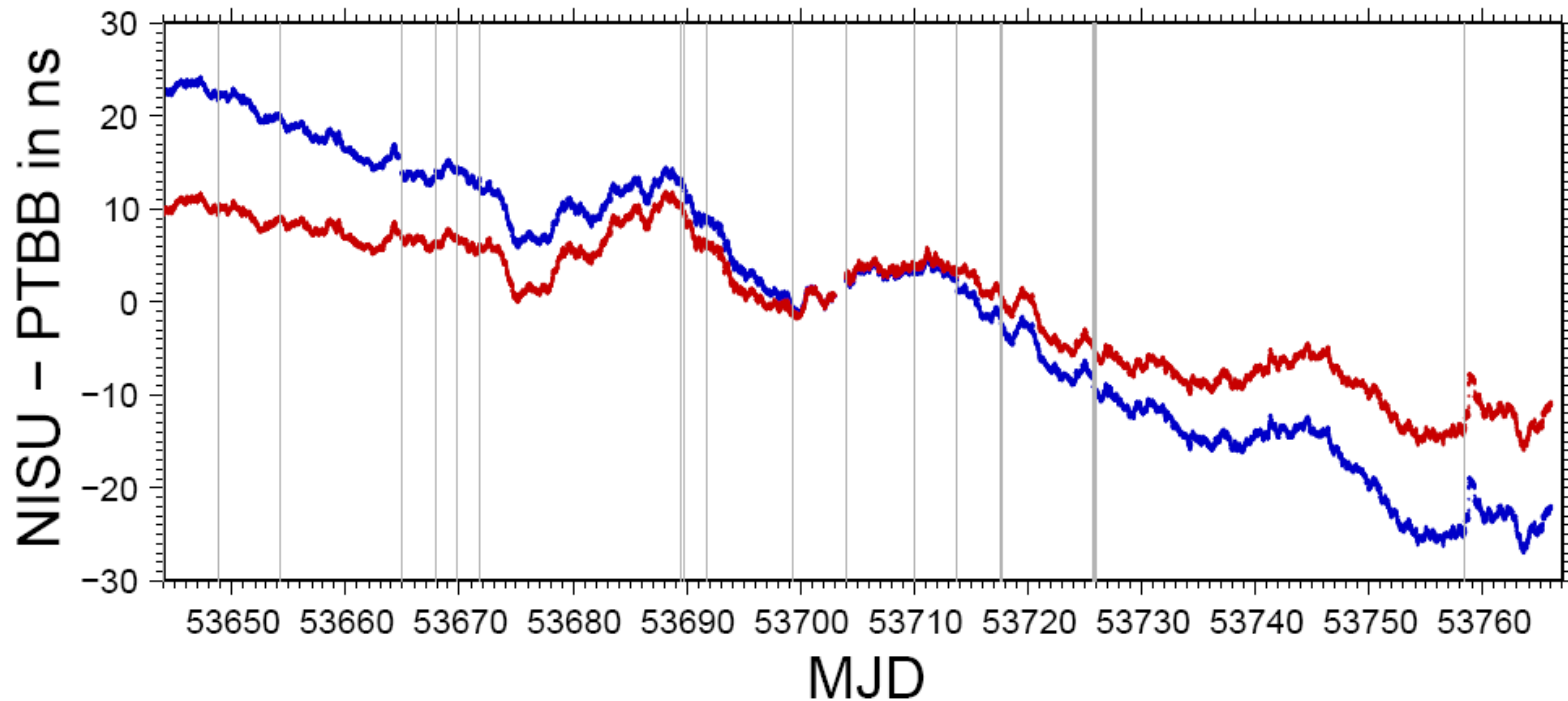

An offset was subtracted for plotting.

Dach 2006

Attachment of H-Maser to GPS Receiver

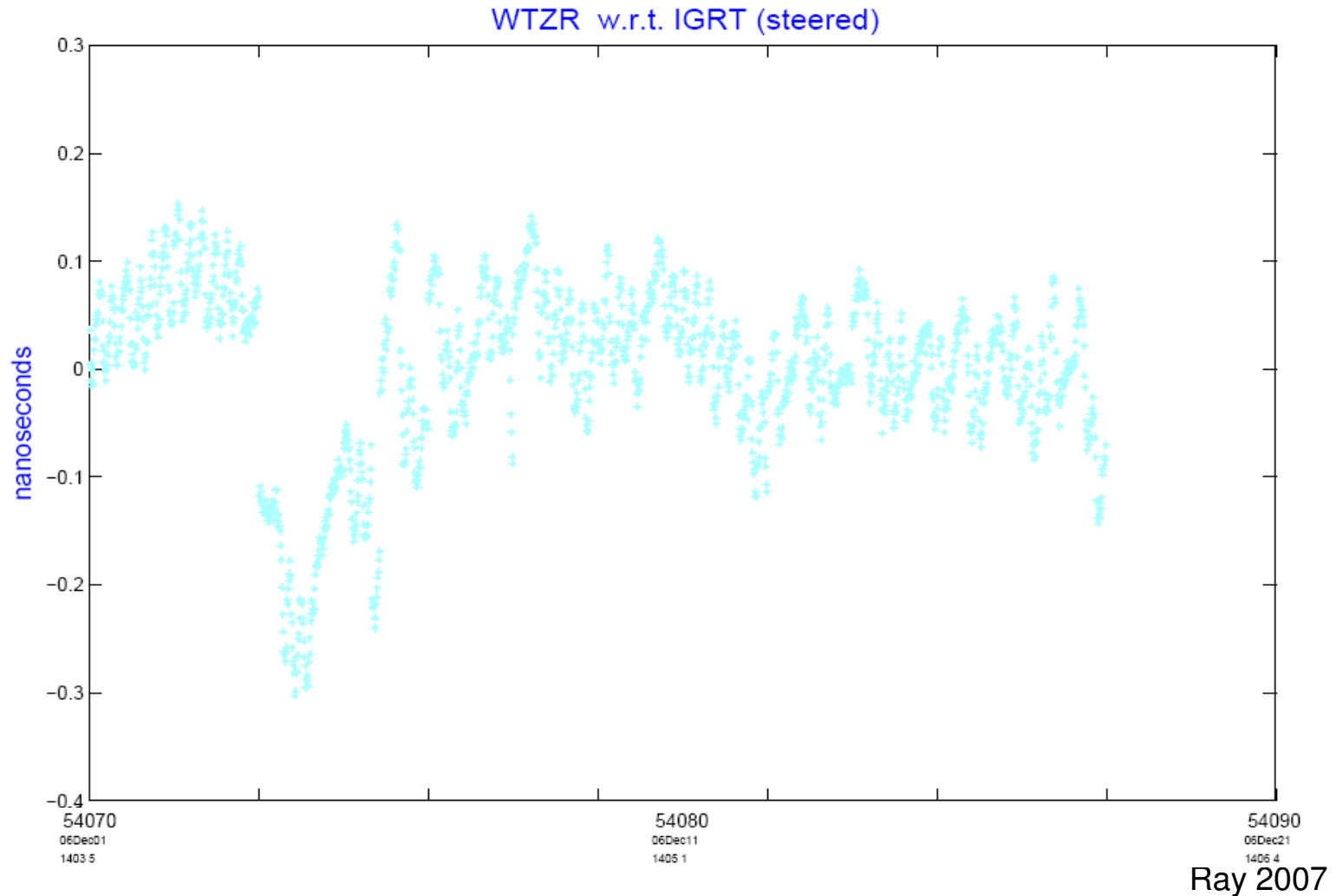

Conclusions

- Synergies in combination
- Steps towards GGOS
- Significant work is already performed and under way
- Potential of combination at observation level not yet investigated
 - consistent modeling
 - common epoch parameters
- Clock modeling in VLBI and GNSS
 - VLBI may profit from clock behavior measured by GNSS at longer integration times
 - GNSS may profit from modeling of masers over short time intervals
 - Technique specific problems are, e.g., attachment of maser to GNSS receiver
- Ambiguity resolution?